

Core Connections, Course 1

Parent Guide with Extra Practice

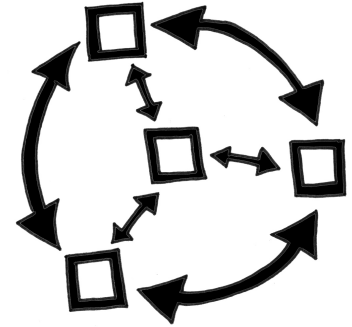

Managing Editors / Authors

Leslie Dietiker, Ph.D. (Both Texts)
Boston University
Boston, MA

Evra Baldinger (First Edition)
Phillip and Sala Burton Academic High School
San Francisco, CA

Barbara Shreve (First Edition)
San Lorenzo High School
San Lorenzo, CA

Michael Kassajian (Second Edition)
CPM Educational Program
Kensington, CA

Misty Nikula (Second Edition)
CPM Educational Program
Portland, OR

Contributing Authors

Brian Hoey
CPM Educational Program
Sacramento, CA

Bob Petersen
CPM Educational Program
Sacramento, CA

Technical Assistants

Sarah Maile
Aubrie Maze
Anna Poehlmann

Cover Art

Jonathan Weast
Sacramento, CA

Program Directors

Elizabeth Coyner
CPM Educational Program
Sacramento, CA

Brian Hoey
CPM Educational Program
Sacramento, CA

Tom Sallee, Ph.D.
Department of Mathematics
University of California, Davis

Leslie Dietiker, Ph.D.
Boston University
Boston, MA

Michael Kassajian
CPM Educational Program
Kensington, CA

Karen Wootton
CPM Educational Program
Odenton, MD

Lori Hamada
CPM Educational Program
Fresno, CA

Judy Kysh, Ph.D.
Departments of Education and
Mathematics San Francisco
State University, CA

Based on *Foundations for Algebra Parent Guide* © 2002
and *Foundations for Algebra Skill Builders* © 2003

Heidi Ackley
Bev Brockhoff
Scott Coyner
Brian Hoey
Robert Petersen
Kristie Sallee

Steve Ackley
Ellen Cafferata
Sara Effenbeck
Judy Kysh
Edwin Reed
Tom Sallee

Elizabeth Baker
Elizabeth Coyner
William Funkhouser
Kris Petersen
Stacy Rocklein
Howard Webb

Technical Assistants

Jennifer Buddenhagen
Bipasha Mukherjee
Bethany Sorbello
Emily Wheelis

Grace Chen
Janelle Petersen
David Trombly

Zoe Kemmerling
Thu Pham
Erika Wallender

Copyright © 2013 by CPM Educational Program. All rights reserved. No part of this publication may be reproduced or transmitted in any form or by any means, electronic or mechanical, including photocopy, recording, or any information storage and retrieval system, without permission in writing from the publisher. Requests for permission should be made in writing to: CPM Educational Program, 9498 Little Rapids Way, Elk Grove, CA 95758. Email: cpm@cpm.org.

1 2 3 4 5 6 19 18 17 16 15 14 13

Printed in the United States of America

ISBN: 978-1-60328-093-8

© 2013 CPM Educational Program. All rights reserved.

Introduction to the Parent Guide with Extra Practice

Welcome to the *Core Connections, Course 1 Parent Guide with Extra Practice*. The purpose of this guide is to assist you should your child need help with homework or the ideas in the course. We believe all students can be successful in mathematics as long as they are willing to work and ask for help when they need it. We encourage you to contact your child's teacher if your student has additional questions that this guide does not answer.

There will be some topics that your child understands quickly and some concepts that may take longer to master. The big ideas of the course take time to learn. This means that students are not necessarily expected to master a concept when it is first introduced. When a topic is first introduced in the textbook, there will be several problems to do for practice. Succeeding lessons and homework assignments will continue to practice the concept or skill over weeks and months so that *mastery will develop over time*.

Practice and discussion are required to understand mathematics. When your child comes to you with a question about a homework problem, often you may simply need to ask your child to read the problem and then ask what the problem is asking. Reading the problem aloud is often more effective than reading it silently. When you are working problems together, have your child talk about the problems. Then have your child practice on his/her own.

Below is a list of additional questions to use when working with your child. These questions do not refer to any particular concept or topic. Some questions may or may not be appropriate for some problems.

- What have you tried? What steps did you take?
- What didn't work? Why didn't it work?
- What have you been doing in class or during this chapter that might be related to this problem?
- What does this word/phrase tell you?
- What do you know about this part of the problem?
- Explain what you know right now.
- What do you need to know to solve the problem?
- How did the members of your study team explain this problem in class?
- What important examples or ideas were highlighted by your teacher?
- Can you draw a diagram or sketch to help you?
- Which words are most important? Why?
- What is your guess/estimate/prediction?
- Is there a simpler, similar problem we can do first?
- How did you organize your information? Do you have a record of your work?
- Have you tried drawing a diagram, making a list, looking for a pattern, etc.?

If your student has made a start at the problem, try these questions.

- What do you think comes next? Why?
- What is still left to be done?
- Is that the only possible answer?
- Is that answer reasonable?
- How could you check your work and your answer?
- How could your method work for other problems?

If you do not seem to be making any progress, you might try these questions.

- Let's look at your notebook, class notes, and Toolkit. Do you have them?
- Were you listening to your team members and teacher in class? What did they say?
- Did you use the class time working on the assignment? Show me what you did.
- Were the other members of your team having difficulty with this as well?
Can you call your study partner or someone from your study team?

This is certainly not a complete list; you will probably come up with some of your own questions as you work through the problems with your child. Ask any question at all, even if it seems too simple to you.

To be successful in mathematics, students need to develop the ability to reason mathematically. To do so, students need to think about what they already know and then connect this knowledge to the new ideas they are learning. Many students are not used to the idea that what they learned yesterday or last week will be connected to today's lesson. Too often students do not have to do much thinking in school because they are usually just told what to do. When students understand that connecting prior learning to new ideas is a normal part of their education, they will be more successful in this mathematics course (and any other course, for that matter). The student's responsibilities for learning mathematics include the following:

- Actively contributing in whole class and study team work and discussion.
- Completing (or at least attempting) all assigned problems and turning in assignments in a timely manner.
- Checking and correcting problems on assignments (usually with their study partner or study team) based on answers and solutions provided in class and online.
- Asking for help when needed from his or her study partner, study team, and/or teacher.
- Attempting to provide help when asked by other students.
- Taking notes and using his/her Toolkit when recommended by the teacher or the text.
- Keeping a well-organized notebook.
- Not distracting other students from the opportunity to learn.

Assisting your child to understand and accept these responsibilities will help him or her to be successful in this course, develop mathematical reasoning, and form habits that will help her/him become a life-long learner.

Additional support for students and parents is provided at the CPM Homework Help site: homework.cpm.org

The website provides a variety of complete solutions, hints, and answers. Some problems refer back to other similar problems. The homework help is designed to assist students to be able to do the problems but not necessarily do the problems for them.

Table of Contents *Core Connections, Course 1*

Chapter 1

Lesson 1.1.3	Describing and Extending Patterns	1
Lesson 1.1.4	Graphical Representations of Data Histograms and Bar Graphs	3
Lessons 1.2.3 and 1.2.4	Types of Numbers	7

Chapter 2

Lesson 2.1.2	Graphical Representations of Data Stem-and-Leaf Plots	8
Lessons 2.3.1 to 2.3.4	Multiplication with Generic Rectangles	9
Lessons 2.3.3 and 2.3.4	Distributive Property	11

Chapter 3

Lesson 3.1.1	Equivalent Fractions	14
Lessons 3.1.2 to 3.1.5	Fraction–Decimal–Percent Equivalents	15
Lesson 3.1.2 Math Note	Operations with Fractions Addition and Subtraction of Fractions	18
Lesson 3.1.6	Ratios	20
Lessons 3.2.1 to 3.2.2	Operations with Integers Addition of Integers	21
Lesson 3.2.3	Absolute Value	24
Lesson 3.2.4	Four-Quadrant Graphing	26

Chapter 4

Lessons 4.1.1 to 4.1.3	Variable Expressions	28
Lessons 4.1.1 to 4.1.3	Using Variables to Generalize	30
Lesson 4.1.3 Math Note	Operations with Fractions Addition and Subtraction of Mixed Numbers	32
Lesson 4.1.3	Substitution and Evaluation of Expressions	34
Lessons 4.2.1 to 4.2.3	Scaling Figures and Scale Factor	36

Chapter 5

Lessons 5.1.1, 5.1.4, 5.2.2	Multiplying Fractions with an Area Model	38
Lessons 5.2.1	Operations with Decimals Multiplication of Decimals and Percents	40
Lessons 5.3.1 to 5.3.4	Area of Polygons and Complex Figures	42

Chapter 6

Lessons 6.1.1 to 6.1.4	Division by Fractions	49
Lesson 6.2.1	Order of Operations	52
Lesson 6.2.3	Algebra Tiles and Perimeter	55
Lesson 6.2.4	Combining Like Terms	57

Chapter 7

Lessons 7.1.1 to 7.1.3	Rates and Unit Rates	59
Lessons 7.2.1 to 7.2.3	Division by Fractions – see Lessons 6.1.1 to 6.1.4	49
Lesson 7.2.3	Operations with Decimals	61
Lesson 7.3.4	Graphing and Solving Inequalities	64

Chapter 8

Lessons 8.1.1 and 8.1.2	Measures of Central Tendency	67
Lessons 8.1.4 and 8.1.5	Graphical Representations of Data Box Plots	70
Lesson 8.3.1	Solving Equations in Context	73
Lesson 8.3.2	Distance, Rate, and Time	76

Chapter 9

Lessons 9.1.1 and 9.1.2	Prisms – Volume and Surface Area	78
Lessons 9.2.1 to 9.2.4	Calculating and Using Percents	82

Students are asked to use their observations and pattern recognition skills to extend patterns and predict the number of dots that will be in a figure that is too large to draw. Later, variables will be used to describe the patterns.

Example

Examine the dot pattern at right. Assuming the pattern continues:

- a. Draw Figure 4.
- b. How many dots will be in Figure 10?

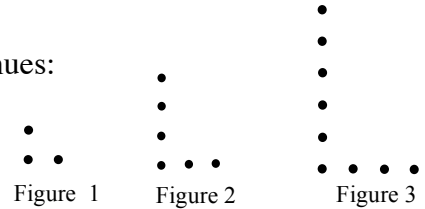

Solution:

The horizontal dots are one more than the figure number and the vertical dots are even numbers (or, twice the figure number).

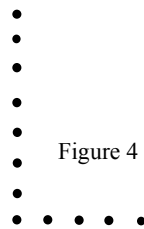
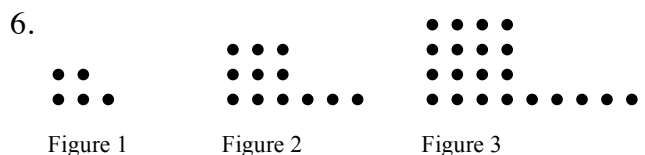
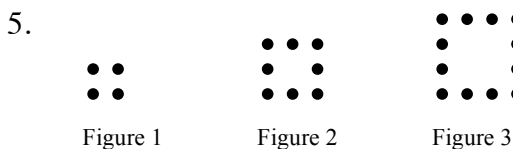
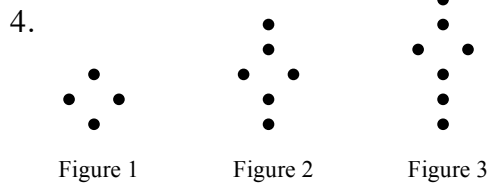
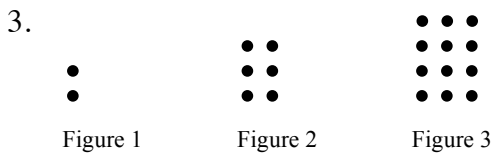
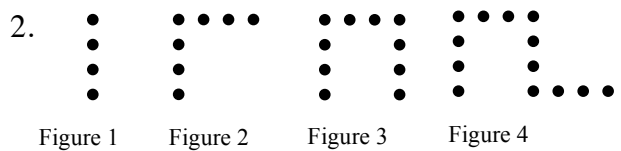
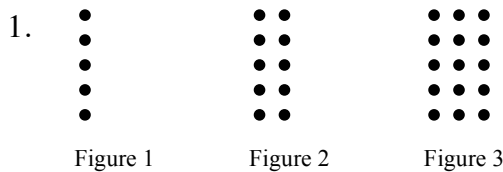

Figure 1 has 3 dots, Figure 2 has 6 dots, and Figure 3 has 9 dots. The number of dots is the figure number multiplied by three.

Figure 10 has 30 dots.

Problems

For each dot pattern, draw the next figure and determine the number of dots in Figure 10.



Answers

1. 50 dots

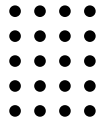

Figure 4

2. 31 dots

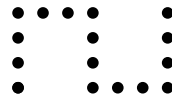

Figure 5

3. 110 dots

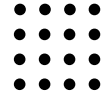

Figure 4

4. 22 dots

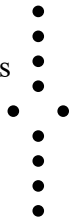

Figure 4

5. 40 dots

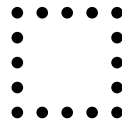

Figure 5

6. 140 dots

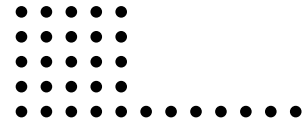

Figure 4

Students represent distributions of single-variable data numerical data using dot plots, stem-and-leaf plots, box plots, and histograms. They represent categorical one-variable data on bar graphs. Each representation communicates information in a slightly different way.

HISTOGRAMS AND BAR GRAPHS

Histograms and bar graphs are visual ways to represent data. Both consist of vertical bars (called bins) with heights that represent the number of data points (called the frequency) in each bin.

Histograms are for displaying distributions of numerical data. In a histogram each bar represents the number of data elements within a certain range of values. All the bars touch each other. Values at the left side of a bin’s range are included in that bin. Each range of values should have the same width.

Bar graphs are for displaying categorical data. In a bar graph each bar represents the number of data elements in a certain category. All the bars are the same width and are separated from each other.

For additional information and examples, see the Math Notes boxes in Lessons 2.1.2 and 2.2.1 of the *Core Connections, Course 1* text. For additional examples and practice, see the *Core Connections, Course 1* Checkpoint 9A materials at the back of the text.

Example 1

The scores for a 25-point quiz are listed below arranged from least to greatest.

7, 7, 12, 13, 15, 16, 16, 16, 18, 19, 20, 20, 20, 21, 21, 22, 23, 24

Using intervals of five points, create a histogram for the class.

See histogram at right. Scores on the right end of the interval are included in the next interval. The interval between 10 and 15 only includes the two scores of 12 and 13. The interval between six scores of 15, 16, 16, 16, 18, and 19.

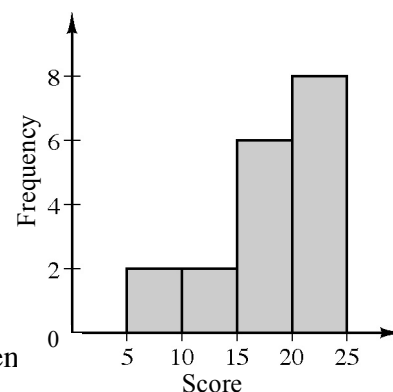

Example 2

Ms. Lim asked each of her students about their favorite kind of pet. Based on their responses, she drew the bar graph at right. Use the bar graph to answer each question.

- What is the favorite pet?
- How many students chose a bird as their favorite pet?
- What was the least favorite pet?
- If every student voted once, how many students are in the class?

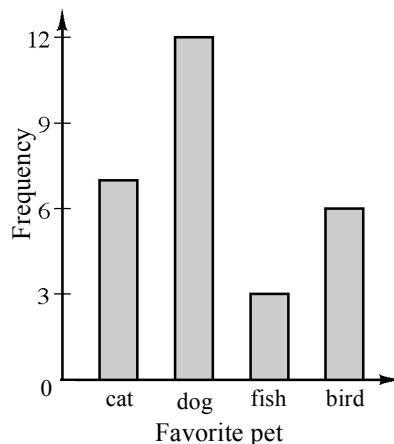

Answers: a. dog b. 6 c. fish d. 28

Problems

- Mr. Diaz surveyed his employees about the time it takes them to get to work. The results are shown in the histogram at right.
 - How many employees completed the survey?
 - How many employees get to work in less than 20 minutes?
 - How many employees get to work in less than 40 minutes?
 - How many employees take 60 minutes to get to work?
- The two sixth grade classes at Vista Middle School voted for their favorite dessert. The results are shown in the bar graph at right for the five favorite choices.
 - What was the favorite dessert and how many students made that choice?
 - How many students selected cake as their favorite dessert?
 - How many students selected yogurt as their favorite?
 - How many more students selected ice cream than pudding?

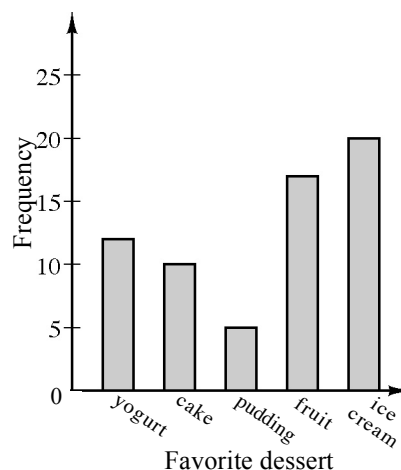
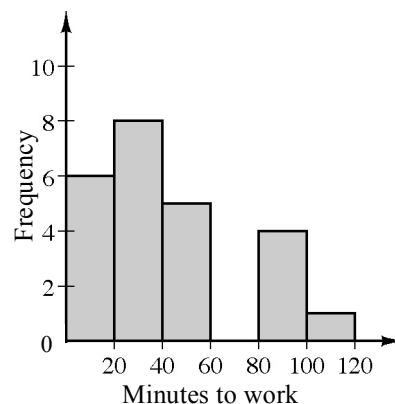

3. Mr. Fernandez asked 30 people at work how many pets they owned. The results are shown at right. Make a histogram to display this data. Use intervals of one pet.

0 pets	5 people
1 pet	8 people
2 pets	10 people
3 pets	3 people
4 pets	2 people
5 pets	1 person
9 pets	1 person

4. During the first week of school Ms. Chan asked her students to name the country where they were born. There were so many different countries she grouped them by continent:

North America: 14 students, South America: 2 students,
Europe: 3 students, Asia: 10 students, Africa: 1 student, Australia: 0 students.

Make a bar graph to display this information.

5. Three coins were tossed 20 times and the number of results that were “heads” each time is shown below:

1, 1, 2, 0, 2, 3, 1, 2, 1, 2, 2, 1, 3, 2, 0, 1, 2, 0, 2, 1

Make a histogram to show the results.

6. The physical education teacher at West Middle School asked the class about their favorite winter activity. Here were the results:

reading: 8 students, ice skating: 4 students, skiing: 6 student,
snowboarding: 11 students, computer activities: 14 students.

Make a bar graph to show the results.

Answers

1. a. 24 b. 6 c. 14 d. 0

2. a. ice cream 20 b. 10
c. 12 d. 15

3.

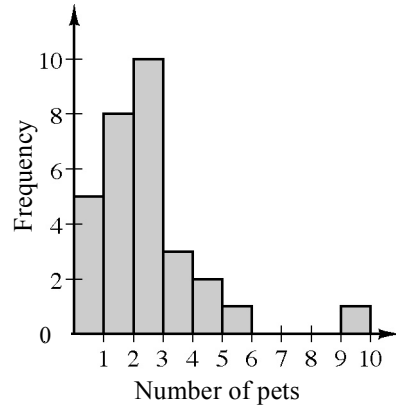

4.

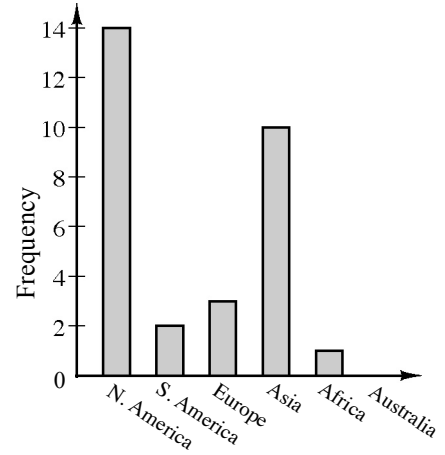

5.

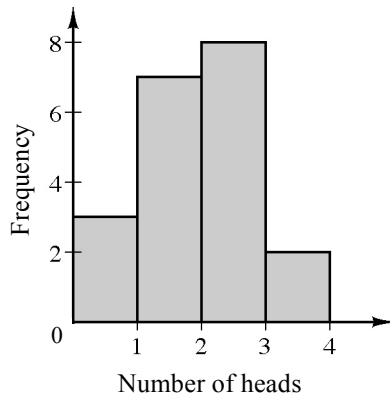

6.

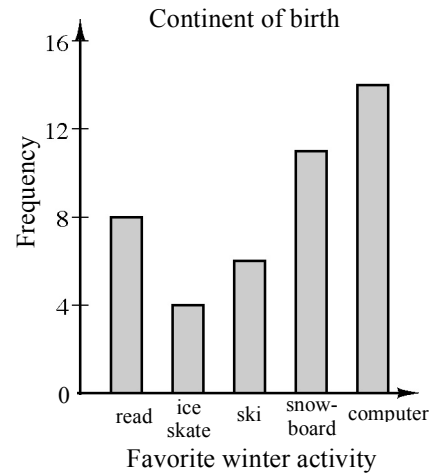

When two or more integers are multiplied together, each number is a factor of the product. Non-negative integers that have exactly two factors, namely, one and itself, are called prime numbers. Except for one and zero, the other non-prime numbers are composite. One has only one factor, so it is neither prime nor composite. It is also the Multiplicative Identity since one multiplied by any number does not change the value. Written in symbols, $1 \cdot n = n$. Zero is the Additive Identity since adding zero to any number does not change the value. Written in symbols, $0 + n = n$.

For more information, see the Math Notes box in Lesson 1.2.3 of the *Core Connections, Course 1* text.

Example 1

Identify each integer as prime, composite, or neither.

- 6 6 has factors of 1, 6, 2, and 3 so 6 is composite.
- 17 17 has factors of 1 and 17 so 17 is prime.
- 1 1 has only 1 as a factor so 1 is neither.

Example 2

For each composite number, factor it into primes and write the number as a product of primes using exponents as possible.

- 24 $24 = 4 \cdot 6 = 2 \cdot 2 \cdot 2 \cdot 3 = 2^3 \cdot 3$
- 45 $45 = 9 \cdot 5 = 3 \cdot 3 \cdot 5 = 3^2 \cdot 5$

Problems

Identify each integer as prime, composite, or neither. For each composite number, factor it into primes and write the number as a product of primes, using exponents as possible.

- | | | | |
|-------|-------|--------|--------|
| 1. 30 | 2. 15 | 3. 16 | 4. 20 |
| 5. 11 | 6. 38 | 7. 29 | 8. 100 |
| 9. 53 | 10. 0 | 11. 54 | 12. 96 |

Answers

- | | | | |
|------------------------|-----------------|-------------------|--------------------|
| 1. $2 \cdot 3 \cdot 5$ | 2. $3 \cdot 5$ | 3. 2^4 | 4. $2^2 \cdot 5$ |
| 5. prime | 6. $2 \cdot 19$ | 7. prime | 8. $2^2 \cdot 5^2$ |
| 9. prime | 10. neither | 11. $2 \cdot 3^3$ | 12. $2^5 \cdot 3$ |

Students represent distributions of single-variable data numerical data using dot plots, stem-and-leaf plots, box plots, and histograms. They represent categorical one-variable data on bar graphs. Each representation communicates information in a slightly different way.

STEM-AND-LEAF-PLOTS

A stem-and-leaf plot is a way to display data that shows the individual values from a set of data and how the values are distributed. The “stem” part on the graph represents all of the digits except the last one. The “leaf” part of the graph represents the last digit of each number.

Read more about stem-and-leaf plots, and how they compare to dot plots and histograms, in the Math Notes in Lesson 2.1.2 and 2.2.1 in the *Core Connections, Course 1* text.

Example 1

Make a stem-and-leaf plot of this set of data: 34, 31, 37, 44, 38, 29, 34, 42, 43, 34, 52, and 41.

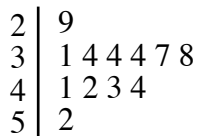

Example 2

Make a stem-and-leaf plot of this set of data: 392, 382, 380, 392, 378, 375, 395, 377, and 377.

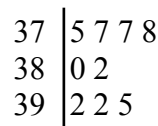

Problems

Make a stem-and-leaf plot of each set of data.

1. 29, 28, 34, 30, 33, 26, 18, and 34.
2. 25, 34, 27, 25, 19, 31, 42, and 30.
3. 80, 89, 79, 84, 95, 79, 89, 67, 82, 76, 92, 89, 81, and 123.
4. 116, 104, 101, 111, 100, 107, 113, 118, 113, 101, 108, 109, 105, 103, and 91.

Answers

1.
$$\begin{array}{r|l}
 1 & 8 \\
 2 & 6\ 8\ 9 \\
 3 & 0\ 3\ 4\ 4
 \end{array}$$
2.
$$\begin{array}{r|l}
 1 & 9 \\
 2 & 5\ 5\ 7 \\
 3 & 0\ 1\ 4\ 5 \\
 4 & 2
 \end{array}$$
3.
$$\begin{array}{r|l}
 6 & 7 \\
 7 & 6\ 9\ 9 \\
 8 & 0\ 1\ 2\ 4\ 9\ 9\ 9 \\
 9 & 2\ 5 \\
 10 & \\
 11 & \\
 12 & 3
 \end{array}$$
4.
$$\begin{array}{r|l}
 9 & 1 \\
 10 & 0\ 1\ 1\ 3\ 4\ 5\ 7\ 8\ 9 \\
 11 & 1\ 3\ 3\ 6\ 8
 \end{array}$$

If a large rectangle is cut into a number of smaller rectangles, then the area of the large rectangle is equal to the sum of the areas of all the smaller rectangles. The idea of breaking a product up into parts is the basis for multiplication using generic rectangles. We say “generic” because the dimensions are not to scale. We use it to help us visualize multiplication and as a way to multiply numbers by using a diagram. Multiplication using rectangle models reinforces the multiplication algorithm and will continue to be used and extended through Algebra 1 and Algebra 2. For additional information, see the Math Notes box in Lesson 2.3.2 of the *Core Connections, Course 1* text.

Example 1

Multiply $23 \cdot 35$ using a generic rectangle.

Since we are multiplying a two-digit number by a two-digit number we need a generic rectangle as shown at right. The numbers to be multiplied are separated (decomposed) based on place value. In this case, for example, 23 has two tens (20) and 3 ones.

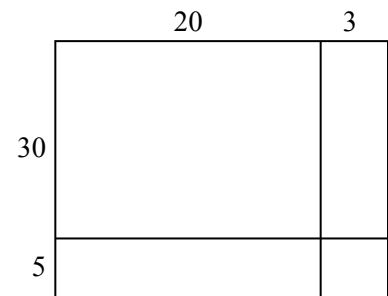

The area of the product (the large rectangle) is equal to the sum of the areas of each of the smaller rectangles. The area of each of the smaller rectangles is found by multiplying its dimensions.

Find the area of each of the smaller rectangles and then sum them together.

$$23 \cdot 35 = (20 + 3)(30 + 5) = 600 + 100 + 90 + 15 = 805$$

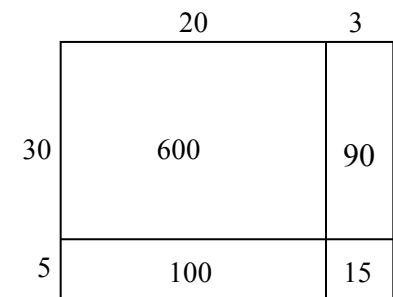

Example 2

Multiply $243 \cdot 25$ using a generic rectangle.

Since we are multiplying a three-digit number by a two-digit number we need six sections in our rectangle. Fill in the areas and add them together to get:

$$243 \cdot 25 = 4000 + 800 + 60 + 1000 + 200 + 15 = 6075$$

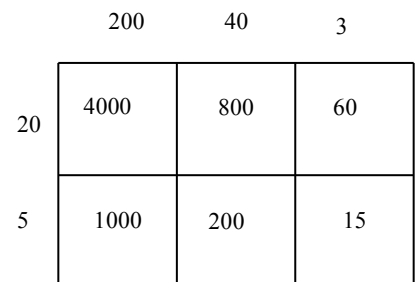

Problems

Use a generic rectangle to find each product.

1. $47 \cdot 52$

2. $38 \cdot 84$

3. $126 \cdot 35$

4. $72 \cdot 39$

5. $67 \cdot 89$

6. $347 \cdot 85$

What multiplication problem does each generic rectangle represent and what is the product?

7.

	6	
30	1500	
	250	

8.

70	
	200
210	15

9.

	7	
30	1800	
	1600	56

Answers

1. 2444

2. 3192

3. 4410

4. 2808

5. 5963

6. 29,495

7. $56 \cdot 35 = 1960$

8. $75 \cdot 43 = 3225$

9. $267 \cdot 38 = 10,146$

The Distributive Property shows how to express sums and products in two ways:
 $a(b + c) = ab + ac$. This can also be written $(b + c)a = ab + ac$.

Factored form
 $a(b + c)$

Distributed form
 $a(b) + a(c)$

Simplified form
 $ab + ac$

To simplify: Multiply each term on the inside of the parentheses by the term on the outside.
 Combine terms if possible.

For additional information, see the Math Notes boxes in Lessons 2.3.4 and 7.3.2 of the *Core Connections, Course 1* text. For additional examples and practice, see the *Core Connections, Course 1* Checkpoint 8A materials.

Example 1

$$\begin{aligned} 2(47) &= 2(40 + 7) \\ &= (2 \cdot 40) + (2 \cdot 7) \\ &= 80 + 14 = 94 \end{aligned}$$

Example 2

$$\begin{aligned} 3(x + 4) &= (3 \cdot x) + (3 \cdot 4) \\ &= 3x + 12 \end{aligned}$$

Example 3

$$\begin{aligned} 4(x + 3y + 1) &= (4 \cdot x) + (4 \cdot 3y) + 4(1) \\ &= 4x + 12y + 4 \end{aligned}$$

Problems

Simplify each expression below by applying the Distributive Property.

- | | | | |
|------------------------|------------------------|-----------------|-----------------|
| 1. $6(9 + 4)$ | 2. $4(9 + 8)$ | 3. $7(8 + 6)$ | 4. $5(7 + 4)$ |
| 5. $3(27) = 3(20 + 7)$ | 6. $6(46) = 6(40 + 6)$ | 7. $8(43)$ | 8. $6(78)$ |
| 9. $3(x + 6)$ | 10. $5(x + 7)$ | 11. $8(x - 4)$ | 12. $6(x - 10)$ |
| 13. $(8 + x)4$ | 14. $(2 + x)5$ | 15. $-7(x + 1)$ | 16. $-4(y + 3)$ |
| 17. $-3(y - 5)$ | 18. $-5(b - 4)$ | 19. $-(x + 6)$ | 20. $-(x + 7)$ |
| 21. $-(x - 4)$ | 22. $-(-x - 3)$ | 23. $x(x + 3)$ | 24. $4x(x + 2)$ |
| 25. $-x(5x - 7)$ | 26. $-x(2x - 6)$ | | |

Answers

- | | | | |
|---|---|-------------------|---------------------|
| 1. $(6 \cdot 9) + (6 \cdot 4) = 54 + 24 = 78$ | 2. $(4 \cdot 9) + (4 \cdot 8) = 36 + 32 = 68$ | | |
| 3. $56 + 42 = 98$ | 4. $35 + 20 = 55$ | 5. $60 + 21 = 81$ | 6. $240 + 36 = 276$ |
| 7. $320 + 24 = 344$ | 8. $420 + 48 = 468$ | 9. $3x + 18$ | 10. $5x + 35$ |
| 11. $8x - 32$ | 12. $6x - 60$ | 13. $4x + 32$ | 14. $5x + 10$ |
| 15. $-7x - 7$ | 16. $-4y - 12$ | 17. $-3y + 15$ | 18. $-5b + 20$ |
| 19. $-x - 6$ | 20. $-x - 7$ | 21. $-x + 4$ | 22. $x + 3$ |
| 23. $x^2 + 3x$ | 24. $4x^2 + 8x$ | 25. $-5x^2 + 7x$ | 26. $-2x^2 + 6x$ |

When the Distributive Property is used to reverse, it is called factoring. Factoring changes a sum of terms (no parentheses) to a product (with parentheses.)

$$ab + ac = a(b + c)$$

To factor: Write the common factor of all the terms outside of the parentheses. Place the remaining factors of each of the original terms inside of the parentheses.

For additional examples and practice, see the *Core Connections, Course 1* Checkpoint 8A materials.

Example 4

$$\begin{aligned} 4x + 8 &= 4 \cdot x + 4 \cdot 2 \\ &= 4(x + 2) \end{aligned}$$

Example 5

$$\begin{aligned} 6x^2 - 9x &= 3x \cdot 2x - 3x \cdot 3 \\ &= 3x(2x - 3) \end{aligned}$$

Example 6

$$\begin{aligned} 6x + 12y + 3 &= 3 \cdot 2x + 3 \cdot 4y + 3 \cdot 1 \\ &= 3(2x + 4y + 1) \end{aligned}$$

Problems

Factor each expression below by using the Distributive Property in reverse.

- | | | | |
|--------------------|--------------------|------------------------|--------------------|
| 1. $6x + 12$ | 2. $5y - 10$ | 3. $8x + 20z$ | 4. $x^2 + xy$ |
| 5. $8m + 24$ | 6. $16y + 40$ | 7. $8m - 2$ | 8. $25y - 10$ |
| 9. $2x^2 - 10x$ | 10. $21x^2 - 63$ | 11. $21x^2 - 63x$ | 12. $15y + 35$ |
| 13. $4x + 4y + 4z$ | 14. $6x + 12y + 6$ | 15. $14x^2 - 49x + 28$ | 16. $x^2 - x + xy$ |

Answers

- | | | | |
|----------------|-----------------|--------------------|----------------|
| 1. $6(x+2)$ | 2. $5(y-2)$ | 3. $4(2x+5z)$ | 4. $x(x+y)$ |
| 5. $8(m+3)$ | 6. $8(2y+5)$ | 7. $4(2m-1)$ | 8. $5(5y-2)$ |
| 9. $2x(x-5)$ | 10. $21(x^2-3)$ | 11. $21x(x-3)$ | 12. $5(3y+7)$ |
| 13. $4(x+y+z)$ | 14. $6(x+2y+1)$ | 15. $7(2x^2-7x+4)$ | 16. $x(x-1+y)$ |

Fractions that name the same value are called equivalent fractions, such as $\frac{2}{3} = \frac{6}{9}$. One method for finding equivalent fractions is to use the Multiplicative Identity (Identity Property of Multiplication), that is, multiplying the given fraction by a form of the number 1 such as $\frac{2}{2}$, $\frac{5}{5}$, etc. In this course we call these fractions a “Giant One.” Multiplying by 1 does not change the value of a number.

For additional information, see the Math Notes box in Lesson 3.1.1 of the *Core Connections, Course 1* text.

Example 1

Find three equivalent fractions for $\frac{1}{2}$.

$$\frac{1}{2} \cdot \frac{2}{2} = \frac{2}{4}$$

$$\frac{1}{2} \cdot \frac{3}{3} = \frac{3}{6}$$

$$\frac{1}{2} \cdot \frac{4}{4} = \frac{4}{8}$$

Example 2

Use the Giant One to find an equivalent fraction to $\frac{7}{12}$ using 96ths: $\frac{7}{12} \cdot \frac{?}{?} = \frac{?}{96}$

Which Giant One do you use?

Since $\frac{96}{12} = 8$, the Giant One is $\frac{8}{8}$: $\frac{7}{12} \cdot \frac{8}{8} = \frac{56}{96}$

Problems

Use the Giant One to find the specified equivalent fraction. Your answer should include the Giant One you use and the equivalent numerator.

1. $\frac{4}{3} \cdot \frac{?}{?} = \frac{?}{15}$

2. $\frac{5}{9} \cdot \frac{?}{?} = \frac{?}{36}$

3. $\frac{9}{2} \cdot \frac{?}{?} = \frac{?}{38}$

4. $\frac{3}{7} \cdot \frac{?}{?} = \frac{?}{28}$

5. $\frac{5}{3} \cdot \frac{?}{?} = \frac{?}{18}$

6. $\frac{6}{5} \cdot \frac{?}{?} = \frac{?}{15}$

Answers

1. $\frac{5}{5}, 20$ 2. $\frac{4}{4}, 20$ 3. $\frac{19}{19}, 171$ 4. $\frac{4}{4}, 12$ 5. $\frac{6}{6}, 30$ 6. $\frac{3}{3}, 18$

Fractions, decimals, and percents are different ways to represent the same portion or number.

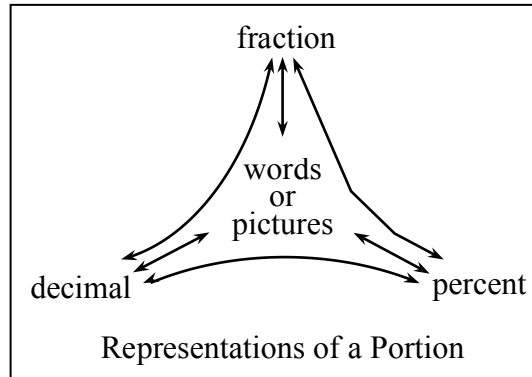

For additional information, see the Math Notes boxes in Lessons 3.1.4 and 3.1.5 of the *Core Connections, Course 1* text. For additional examples and practice, see the *Core Connections, Course 1* Checkpoint 5 materials.

Examples

Decimal to percent:

Multiply the decimal by 100.

$$(0.81)(100) = 81\%$$

Fraction to percent:

Write a proportion to find an equivalent fraction using 100 as the denominator.

The numerator is the percent.

$$\frac{4}{5} = \frac{x}{100} \text{ so } \frac{4}{5} = \frac{80}{100} = 80\%$$

Decimal to fraction:

Use the digits in the decimal as the numerator.

Use the decimal place value name as the denominator. Simplify as needed.

a. $0.2 = \frac{2}{10} = \frac{1}{5}$

b. $0.17 = \frac{17}{100}$

Percent to decimal:

Divide the percent by 100.

$$43\% \div 100 = 0.43$$

Percent to fraction:

Use 100 as the denominator. Use the percent as the numerator. Simplify as needed.

$$22\% = \frac{22}{100} = \frac{11}{50}$$

$$56\% = \frac{56}{100} = \frac{14}{25}$$

Fraction to decimal:

Divide the numerator by the denominator.

$$\frac{3}{8} = 3 \div 8 = 0.375 \quad \frac{5}{8} = 5 \div 8 = 0.625$$

$$\frac{3}{11} = 3 \div 11 = 0.2727\dots = 0.\overline{27}$$

Problems

Convert the fraction, decimal, or percent as indicated.

1. Change $\frac{1}{4}$ to a decimal.
2. Change 50% into a fraction in lowest terms.
3. Change 0.75 to a fraction in lowest terms.
4. Change 75% to a decimal.
5. Change 0.38 to a percent.
6. Change $\frac{1}{5}$ to a percent.
7. Change 0.3 to a fraction.
8. Change $\frac{1}{8}$ to a decimal.
9. Change $\frac{1}{3}$ to a decimal.
10. Change 0.08 to a percent.
11. Change 87% to a decimal.
12. Change $\frac{3}{5}$ to a percent.
13. Change 0.4 to a fraction in lowest terms.
14. Change 65% to a fraction in lowest terms.
15. Change $\frac{1}{9}$ to a decimal.
16. Change 125% to a fraction in lowest terms.
17. Change $\frac{8}{5}$ to a decimal.
18. Change 3.25 to a percent.
19. Change $\frac{1}{16}$ to a decimal.
Change the decimal to a percent.
20. Change $\frac{1}{7}$ to a decimal.
21. Change 43% to a fraction.
Change the fraction to a decimal.
22. Change 0.375 to a percent.
Change the percent to a fraction.
23. Change $\frac{7}{8}$ to a decimal.
Change the decimal to a percent.
24. Change $0.\overline{12}$ to a fraction
25. Change $0.\overline{175}$ to a fraction

Answers

- | | | | |
|------------------------------------|---------------------------------------|-------------------|-------------------------------------|
| 1. 0.25 | 2. $\frac{1}{2}$ | 3. $\frac{3}{4}$ | 4. 0.75 |
| 5. 38% | 6. 20% | 7. $\frac{3}{10}$ | 8. 0.125 |
| 9. $0.3\bar{3}$ | 10. 8% | 11. 0.87 | 12. 60% |
| 13. $\frac{2}{5}$ | 14. $\frac{13}{20}$ | 15. $0.1\bar{1}$ | 16. $\frac{5}{4}$ or $1\frac{1}{4}$ |
| 17. 1.6 | 18. 325% | 19. 0.0625; 6.25% | 20. $0.\overline{142859}$ |
| 21. $\frac{43}{100}$; 0.43 | 22. $37\frac{1}{2}\%$; $\frac{3}{8}$ | 23. 0.875; 87.5% | |
| 24. $\frac{12}{99} = \frac{4}{33}$ | 25. $\frac{175}{999}$ | | |

ADDITION AND SUBTRACTION OF FRACTIONS

Before fractions can be added or subtracted, the fractions must have the same denominator, that is, a common denominator. We will present two methods for adding or subtracting fractions.

AREA MODEL METHOD

Step 1: Copy the problem. $\frac{1}{3} + \frac{1}{2}$

Step 2: Draw and divide equal-sized rectangles for each fraction. One rectangle is cut vertically into an equal number of pieces based on the first denominator (bottom). The other is cut horizontally, using the second denominator. The number of shaded pieces in each rectangle is based on the numerator (top). Label each rectangle, with the fraction it represents.

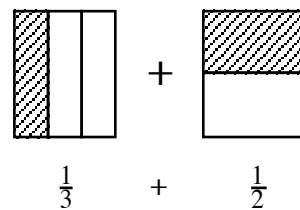

Step 3: Superimpose the lines from each rectangle onto the other rectangle, as if one rectangle is placed on top of the other one.

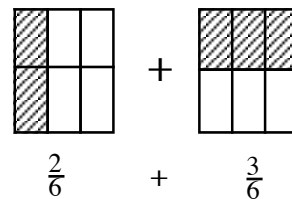

Step 4: Rename the fractions as sixths, because the new rectangles are divided into six equal parts. Change the numerators to match the number of sixths in each figure.

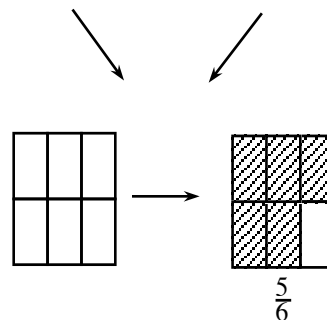

Step 5: Draw an empty rectangle with sixths, then combine all sixths by shading the same number of sixths in the new rectangle as the total that were shaded in both rectangles from the previous step.

Example 1

$\frac{1}{2} + \frac{2}{5}$ can be modeled as:

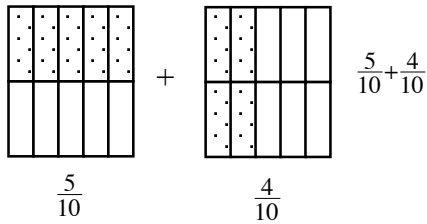
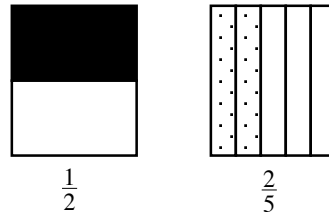

so

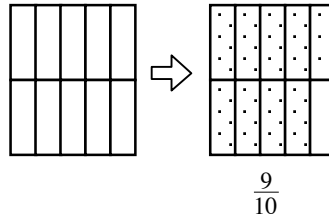

Thus, $\frac{1}{2} + \frac{2}{5} = \frac{9}{10}$.

Example 2

$\frac{1}{2} + \frac{4}{5}$ would be:

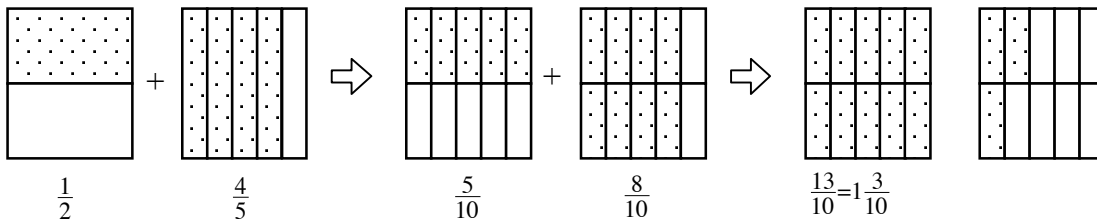

Problems

Use the area model method to add the following fractions.

1. $\frac{3}{4} + \frac{1}{5}$

2. $\frac{1}{3} + \frac{2}{7}$

3. $\frac{2}{3} + \frac{3}{4}$

Answers

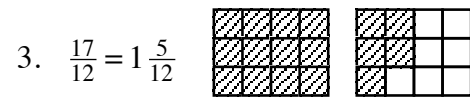
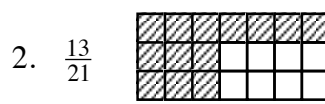

A ratio is a comparison of two quantities by division. It can be written in several ways:

$$\frac{65 \text{ miles}}{1 \text{ hour}}, \text{ 65 miles: 1 hour, or 65 miles to 1 hour}$$

For additional information see the Math Notes box in Lesson 4.2.4 of the *Core Connections, Course 1* text.

Example

A bag contains the following marbles: 7 clear, 8 red and 5 blue. The following ratios may be stated:

- Ratio of blue to total number of marbles $\Rightarrow \frac{5}{20} = \frac{1}{4}$.
- Ratio of red to clear $\Rightarrow \frac{8}{7}$.
- Ratio of red to blue $\Rightarrow \frac{8}{5}$.
- Ratio of blue to red $\Rightarrow \frac{5}{8}$.

Problems

- Molly's favorite juice drink is made by mixing 3 cups of apple juice, 5 cups of cranberry juice, and 2 cups of ginger ale. State the following ratios:
 - Ratio of cranberry juice to apple juice.
 - Ratio of ginger ale to apple juice.
 - Ratio of ginger ale to finished juice drink (the mixture).
- A 40-passenger bus is carrying 20 girls, 16 boys, and 2 teachers on a field trip to the state capital. State the following ratios:
 - Ratio of girls to boys.
 - Ratio of boys to girls.
 - Ratio of teachers to students.
 - Ratio of teachers to passengers.
- It is important for Molly (from problem one) to keep the ratios the same when she mixes larger or smaller amounts of the drink. Otherwise, the drink does not taste right. If she needs a total of 30 cups of juice drink, how many cups of each liquid should be used?
- If Molly (from problem one) needs 25 cups of juice drink, how many cups of each liquid should be used? Remember that the ratios must stay the same.

Answers

- a. $\frac{5}{3}$ b. $\frac{2}{3}$ c. $\frac{2}{10} = \frac{1}{5}$ 2. a. $\frac{20}{16} = \frac{5}{4}$ b. $\frac{16}{20} = \frac{4}{5}$ c. $\frac{2}{36}$ d. $\frac{2}{38}$
- 9 c. apple, 15 c. cranberry, 4. $7\frac{1}{2}$ c. apple, $12\frac{1}{2}$ c. cranberry, 5 c. ginger ale
6 c. ginger ale

ADDITION OF INTEGERS

Students review addition of integers using two concrete models: movement along a number line and positive and negative integer tiles.

To add two integers using a number line, start at the first number and then move the appropriate number of spaces to the right or left depending on whether the second number is positive or negative, respectively. Your final location is the sum of the two integers.

To add two integers using integer tiles, a positive number is represented by the appropriate number of (+) tiles and a negative number is represented by the appropriate number of (-) tiles. To add two integers start with a tile representation of the first integer in a diagram and then place into the diagram a tile representative of the second integer. Any equal number of (+) tiles and (-) tiles makes “zero” and can be removed from the diagram. The tiles that remain represent the sum. For additional information, see the Math Notes box in Lesson 3.2.3 of the *Core Connections, Course 1* text.

Example 1

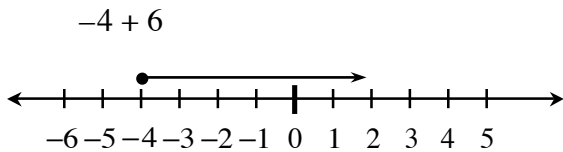

$-4 + 6 = 2$

Example 2

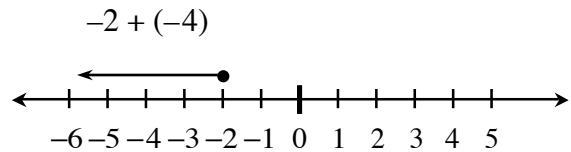

$-2 + (-4) = -6$

Example 3

$5 + (-6)$

Start with tiles representing the first number.

+ + + + +

Add to the diagram tiles representing the second number.

+ + + + +
- - - - -

Circle the zero pairs.
-1 is the answer.

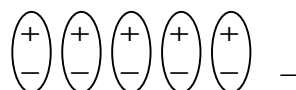

$5 + (-6) = -1$

Example 4

$-3 + 7$

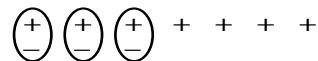

$-3 + 7 = 4$

ADDITION OF INTEGERS IN GENERAL

When you add integers using the tile model, zero pairs are only formed if the two numbers have different signs. After you circle the zero pairs, you count the uncircled tiles to find the sum. If the signs are the same, no zero pairs are formed, and you find the sum of the tiles. Integers can be added without building models by using the rules below.

- If the signs are the same, add the numbers and keep the same sign.
- If the signs are different, ignore the signs (that is, use the absolute value of each number.) Subtract the number closest to zero from the number farthest from zero. The sign of the answer is the same as the number that is farthest from zero, that is, the number with the greater absolute value.

Example

For $-4 + 2$, -4 is farther from zero on the number line than 2 , so subtract: $4 - 2 = 2$. The answer is -2 , since the “4,” that is, the number farthest from zero, is negative in the original problem.

Problems

Use either model or the rules above to find these sums.

1. $4 + (-2)$
2. $6 + (-1)$
3. $7 + (-7)$
4. $-10 + 6$
5. $-8 + 2$
6. $-12 + 7$
7. $-5 + (-8)$
8. $-10 + (-2)$
9. $-11 + (-16)$
10. $-8 + 10$
11. $-7 + 15$
12. $-26 + 12$
13. $-3 + 4 + 6$
14. $56 + 17$
15. $7 + (-10) + (-3)$
16. $-95 + 26$
17. $35 + (-6) + 8$
18. $-113 + 274$
19. $105 + (-65) + 20$
20. $-6 + 2 + (-4) + 3 + 5$
21. $5 + (-3) + (-2) + (-8)$
22. $-6 + (-3) + (-2) + 9$
23. $-6 + (-3) + 9$
24. $20 + (-70)$
25. $12 + (-7) + (-8) + 4 + (-3)$
26. $-26 + (-13)$
27. $-16 + (-8) + 9$
28. $12 + (-13) + 18 + (-16)$
29. $50 + (-70) + 30$
30. $19 + (-13) + (-5) + 20$

Answers

- | | | | | | |
|--------|---------|---------|---------|--------|---------|
| 1. 2 | 2. 5 | 3. 0 | 4. -4 | 5. -6 | 6. -5 |
| 7. -13 | 8. -12 | 9. -27 | 10. 2 | 11. 8 | 12. -14 |
| 13. 7 | 14. 73 | 15. -6 | 16. -69 | 17. 37 | 18. 161 |
| 19. 60 | 20. 0 | 21. -8 | 22. -2 | 23. 0 | 24. -50 |
| 25. -2 | 26. -39 | 27. -15 | 28. 1 | 29. 10 | 30. 21 |

The absolute value of a number is the distance of the number from zero. Since the absolute value represents a distance, without regard to direction, absolute value is always non-negative.

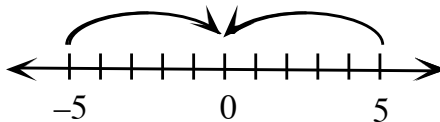

The symbol for absolute value is $| \ |$. On the number line above, both 5 and -5 are 5 units from zero. This distance is displayed as $|-5| = 5$ and is read, “The absolute value of negative five equals five.” Similarly, $|5| = 5$ means, “The absolute value of five is five.”

$|x| = 5$ means that x could be *either* 5 or -5 because both of those points are five units from zero.

The problem $|x| = -5$ has no solution because the absolute value of a number has to be positive. Do not confuse this fact when a negative sign appears outside the absolute value symbol.

For additional information, see the Math Notes box in Lesson 3.2.2 of the *Core Connections, Course 1* text.

Examples

- a. $|-6| = 6$ b. $|7| = 7$ c. $|x| = 9 \Rightarrow x = -9$ or 9
- d. $|x| = -3 \Rightarrow$ no solution e. $-|x| = -3 \Rightarrow x = -3$ or 3 f. $|3 - 8| = |-5| = 5$

Part (d) has no solution, since any absolute value is positive. In part (e), the problem asks for “the opposite of $|x|$,” which is negative.

Problems

Determine the absolute value or the values of x .

1. $|-11|$ 2. $|12|$ 3. $|x| = 4$ 4. $|x| = 16$ 5. $|x| = 24$
6. $|x| = 13$ 7. $|-9|$ 8. $|x| = -13$ 9. $-|x| = -13$ 10. $-|7|$
11. $|x| = 7$ 12. $|-7|$ 13. $|5 - 8|$ 14. $|-6 - 3|$ 15. $|-6 + 3|$

Make a table using x -values from -4 to 4 to draw a graph of each equation.

16. $y = |x|$ 17. $y = |x - 2|$ 18. $y = |x + 2|$ 19. $y = |x| + 2$ 20. $y = -|x|$

Answers

1. 11 2. 12 3. 4, -4 4. 16, -16 5. 24, -24
6. 13, -13 7. 9 8. no solution 9. 13, -13 10. -7
11. 7, -7 12. 7 13. 3 14. 9 15. 3
16. 17. 18. 19. 20.

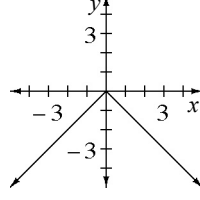
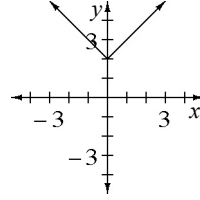
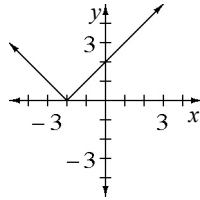
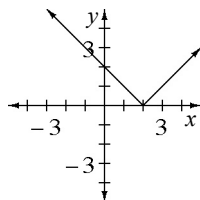
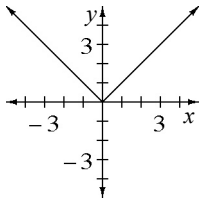

The graphing that was started in earlier grades is now extended to include negative values, and students will graph algebraic equations with two variables. For addition information, see problem 3-122 in the *Core Connections, Course 1* text.

GRAPHING POINTS

Points on a coordinate graph are identified by two numbers in an ordered pair written as (x, y) . The first number is the x -coordinate of the point and the second number is the y -coordinate. Taken together, the two coordinates name exactly one point on the graph. The examples below show how to place a point on an xy -coordinate graph.

Example 1

Graph point $A(2, -3)$.

Go right 2 units from the origin $(0, 0)$, then go down 3 units. Mark the point.

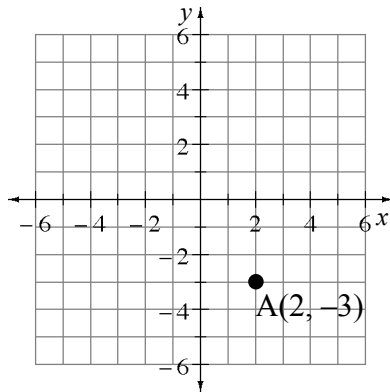

Example 2

Plot the point $C(-4, 0)$ on a coordinate grid.

Go to the left from the origin 4 units, but do not go up or down. Mark the point.

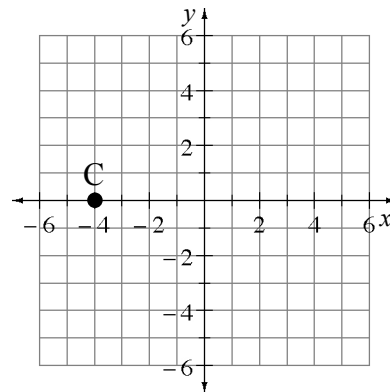

Problems

- Name the coordinate pair for each point shown on the grid below.
- Use the ordered pair to locate each point on a coordinate grid. Place a “dot” at each point and label it with its letter name.

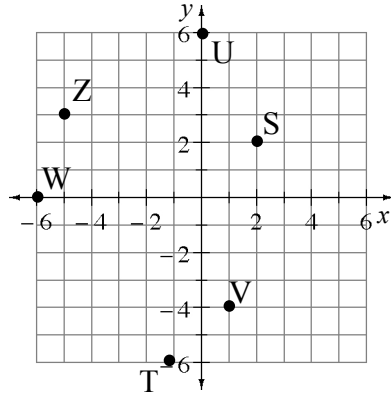

$K(0, -4)$

$L(-5, 0)$

$M(-2, -3)$

$N(-2, 3)$

$O(2, -3)$

$P(-4, -6)$

$Q(4, -5)$

$R(-5, -4)$

$T(-1, -6)$

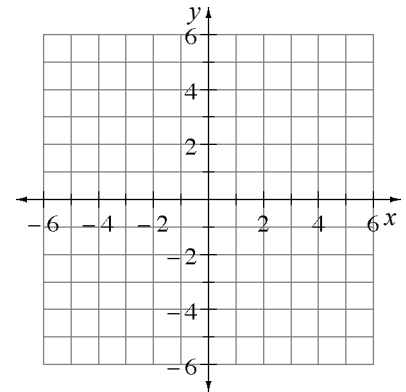

Answers

- $S(2, 2)$
 - $T(-1, -6)$
 - $U(0, 6)$
 - $V(1, -4)$
 - $W(-6, 0)$
 - $Z(-5, 3)$

2.

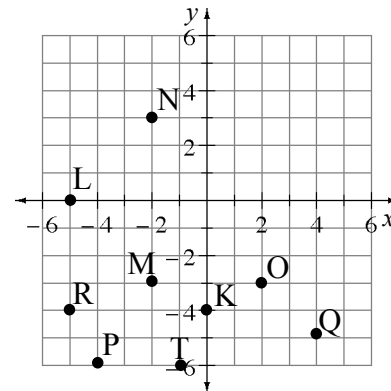

A variable is a symbol used to represent one or more numbers. It is common to use letters of the alphabet for variables. The value of a variable used several times in one expression must be the same.

Example 1

If the unknown distance of Cecil's hop is represented by the variable h , write an expression for:

- Three equal hops $\Rightarrow h+h+h$ or $3h$
- Five equal hops $\Rightarrow h+h+h+h+h$ or $5h$
- Two equal hops and walking 3 feet $\Rightarrow h+h+3$ or $2h+3$

Example 2

If the unknown cost of a banana is b , and the unknown cost of an apple is a , write an expression for the cost of:

- Three bananas and two apples $\Rightarrow b+b+b+a+a$ or $3b+2a$
- One banana and 3 apples $\Rightarrow b+a+a+a$ or $b+3a$
- One banana, one apple, a \$2 item, and a \$3 item $\Rightarrow b+a+2+3$ or $b+a+5$

Problems

If the unknown distance of Cecil's jump is represented by J , write an expression for:

1. Three jumps
2. Six jumps
3. Four jumps and walking 5 feet
4. Walking 3 feet, two jumps, walking 2 feet

If the unknown distance of Cecil's jump is represented by J , and the unknown distance of Cecil's hop is represented by H , write an expression for:

5. Two jumps and two hops
6. One jump, three hops, and two jumps
7. One jump, three hops and walking 7 feet
8. Walking 6 feet, three hops, and two jumps

If the unknown cost of a taco is T , and the unknown cost of a carton of milk is M , write an expression for the cost of:

9. Three tacos and two milks
10. One taco and four milks
11. One taco, one milk and two tacos, one milk
12. Two tacos, one milk, and a \$2 item

Answers

1. $J + J + J = 3J$
2. $J + J + J + J + J + J = 6J$
3. $J + J + J + J + 5 = 4J + 5$
4. $3 + J + J + 2 = 2J + 5$
5. $J + J + H + H = 2J + 2H$
6. $J + H + H + H + J + J = 3J + 3H$
7. $J + H + H + H + 7 = J + 3H + 7$
8. $6 + H + H + H + J + J = 3H + 2J + 6$
9. $3T + 2M$
10. $T + 4M$
11. $T + M + 2T + M = 3T + 2M$
12. $2T + M + 2$

Previously, students extended patterns and predicted subsequent figures. Now students use their knowledge of variables to generalize the pattern they observe. For additional information, see the Math Notes box in Lesson 4.2.1 of the *Core Connections, Course 1* text.

Example 1

Examine the dot pattern below. Draw the next figure, state the number of dots in Figure 15, and give a variable expression for the number of dots in figure “ n .”

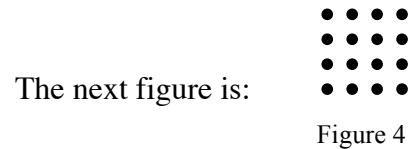
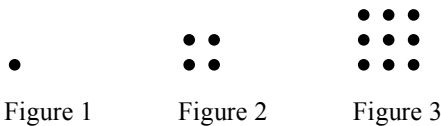

Each figure is a square with a side length that is the same as the figure number, so Figure 15 has $15 \cdot 15 = 225$ dots and figure n would have $n \cdot n = n^2$ dots.

Example 2

Examine the dot pattern below. Draw the next figure, state the number of dots in Figure 15, and give a variable expression for the number of dots in figure “ n .”

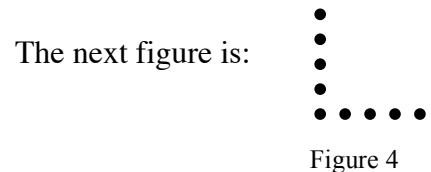
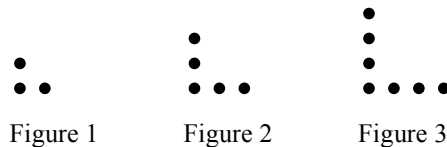

Each figure is an L shape with the number of dots one more than twice the figure number of dots so figure 15 has $15 + 15 + 1 = 31$ dots. Figure n would have $2n + 1$ dots. Another way to see the pattern is as the figure number plus “the figure number plus 1.” This pattern then gives $15 + 16 = 31$ for Figure 15 and $n + (n + 1)$ for Figure n . Of course, $n + (n + 1) = 2n + 1$.

Problems

Examine each dot pattern below. Draw the next figure, tell the number of dots in figure 15, and give a variable expression for the number of dots in figure “ n .”

1.

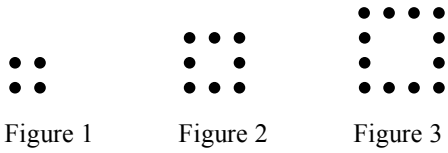

2.

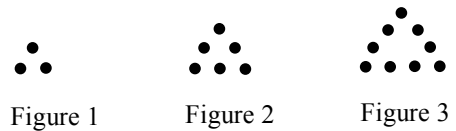

3.

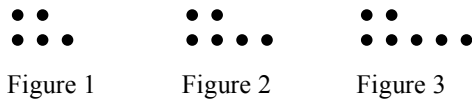

4.

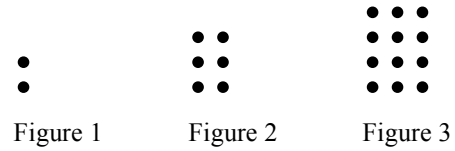

5.

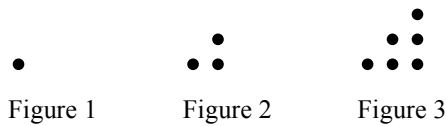

Answers Note: In each answer, n represents the figure number.

1.

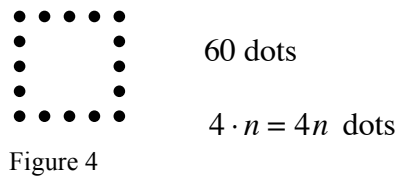

2.



3.

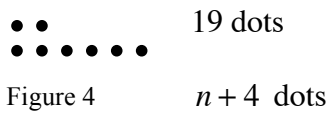

4.

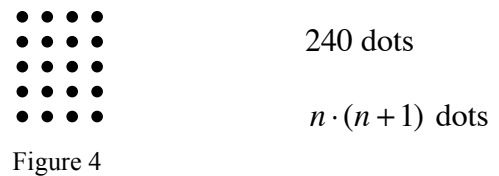

The base of each figure is 4 dots, plus the number of dots that matches the figure number.

5.

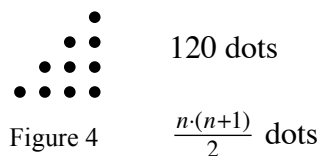

The figures in this pattern are half of the figures in problem 4.

ADDITION AND SUBTRACTION OF MIXED NUMBERS

To subtract mixed numbers, change the mixed numbers into fractions greater than one, find a common denominator, then subtract. Other strategies are also possible. For additional information, see the Math Notes box in Lesson 4.1.3 of the *Core Connections, Course 1* text. For additional examples and practice, see the *Core Connections, Course 1* Checkpoint 4 materials.

Example

Find the difference: $3\frac{1}{5} - 1\frac{2}{3}$

$$\begin{aligned} 3\frac{1}{5} &= \frac{16}{5} \cdot \frac{3}{3} = \frac{48}{15} \\ -1\frac{2}{3} &= \frac{5}{3} \cdot \frac{5}{5} = -\frac{25}{15} \\ &= \frac{23}{15} = 1\frac{8}{15} \end{aligned}$$

Problems

Find each difference.

1. $2\frac{1}{2} - 1\frac{3}{4}$

2. $4\frac{1}{3} - 3\frac{5}{6}$

3. $1\frac{1}{6} - \frac{3}{4}$

4. $5\frac{2}{5} - 3\frac{2}{3}$

5. $7 - 1\frac{2}{3}$

6. $5\frac{3}{8} - 2\frac{2}{3}$

Answers

1. $\frac{5}{2} - \frac{7}{4} \Rightarrow \frac{10}{4} - \frac{7}{4} \Rightarrow \frac{3}{4}$

2. $\frac{13}{3} - \frac{23}{6} \Rightarrow \frac{26}{6} - \frac{23}{6} \Rightarrow \frac{3}{6}$ or $\frac{1}{2}$

3. $\frac{7}{6} - \frac{3}{4} \Rightarrow \frac{14}{12} - \frac{9}{12} \Rightarrow \frac{5}{12}$

4. $\frac{27}{5} - \frac{11}{3} \Rightarrow \frac{81}{15} - \frac{55}{15} \Rightarrow \frac{26}{15}$ or $1\frac{11}{15}$

5. $\frac{7}{1} - \frac{5}{3} \Rightarrow \frac{21}{3} - \frac{5}{3} \Rightarrow \frac{16}{3}$ or $5\frac{1}{3}$

6. $\frac{43}{8} - \frac{8}{3} \Rightarrow \frac{129}{24} - \frac{64}{24} \Rightarrow \frac{65}{24}$ or $2\frac{17}{24}$

To add mixed numbers, it is possible to change the mixed numbers into fractions greater than one, find a common denominator, then add. Many times it is more efficient to add the whole numbers, add the fractions after getting a common denominator, and then simplify the answer. For additional information, see the Math Notes box in Lesson 4.1.3 of the *Core Connections, Course 1* text. For additional examples and practice, see the *Core Connections, Course 1* Checkpoint 4 materials.

Example

Find the sum: $8\frac{3}{4} + 4\frac{2}{5}$

$$\begin{array}{r} 8\frac{3}{4} = 8 + \frac{3}{4} \cdot \frac{5}{5} = 8\frac{15}{20} \\ +4\frac{2}{5} = 4 + \frac{2}{5} \cdot \frac{4}{4} = +4\frac{8}{20} \\ \hline 12\frac{23}{20} = 13\frac{3}{20} \end{array}$$

Problems

Find each sum.

1. $5\frac{3}{4} + 3\frac{1}{6}$

2. $5\frac{2}{3} + 8\frac{3}{8}$

3. $4\frac{4}{9} + 5\frac{2}{3}$

4. $1\frac{2}{5} + 3\frac{5}{6}$

5. $4\frac{1}{2} + 5\frac{3}{8}$

6. $5\frac{4}{7} + 3\frac{2}{3}$

Answers

1. $8\frac{11}{12}$

2. $13\frac{25}{24} = 14\frac{1}{24}$

3. $9\frac{10}{9} = 10\frac{1}{9}$

4. $4\frac{37}{30} = 5\frac{7}{30}$

5. $9\frac{7}{8}$

6. $8\frac{26}{21} = 9\frac{5}{21}$

Substitution is replacing one symbol with an equivalent symbol (a number, a variable, or an expression). One application of the substitution property is replacing a variable name with a number in an expression or equation. A variable is a letter used to represent one or more numbers (or other algebraic expression). The numbers are the values of the variable. A variable expression has numbers and variables with arithmetic operations performed on it.

In general, if $a = b$, then a may replace b and b may replace a .

After numerical substitutions have been made, following the order of operations and doing the arithmetic will correctly evaluate the expression.

For additional information, see the Math Notes box in Lesson 4.2.2 of the *Core Connections, Course 1* text. For additional examples and practice, see the *Core Connections, Course 1* Checkpoint 8A materials.

Examples

Evaluate each variable expression for $x = 3$.

a. $5x \Rightarrow 5(3) \Rightarrow 15$

b. $x + 10 \Rightarrow (3) + 10 \Rightarrow 13$

c. $\frac{18}{x} \Rightarrow \frac{18}{3} \Rightarrow 6$

d. $\frac{x}{3} \Rightarrow \frac{3}{3} \Rightarrow 1$

e. $3x - 5 \Rightarrow 3(3) - 5 \Rightarrow 9 - 5 \Rightarrow 4$

f. $5x + 3x \Rightarrow 5(3) + 3(3) \Rightarrow 15 + 9 \Rightarrow 24$

Problems

Evaluate each of the variable expressions below for $x = -4$ and $y = 3$. Be sure to follow the Order of Operations as you simplify each expression.

1. $x + 4$

2. $x - 1$

3. $x + y + 3$

4. $y - 3 + x$

5. $x^2 - 5$

6. $-x^2 + 5$

7. $x^2 + 4x - 3$

8. $-3x^2 + 2x$

9. $x + 3 + 2y$

10. $y^2 + 3x - 2$

11. $x^2 + y^2 + 3^2$

12. $2^2 + y^2 - 2x^2$

Evaluate the expressions below using the values of the variables in each problem. These problems ask you to evaluate each expression twice, once with each of the values.

13. $3x^2 - 2x + 5$ for $x = -3$ and $x = 4$ 14. $2x^2 - 3x + 6$ for $x = -2$ and $x = 5$

15. $-3x^2 + 7$ for $x = -3$ and $x = 2$ 16. $-2x^2 + 5$ for $x = -4$ and $x = 5$

Evaluate the variable expressions for $x = -4$ and $y = 3$.

17. $x(x + 3x)$

18. $2(x + 2x)$

19. $2(x + y) + 4\left(\frac{y+2}{x}\right)$

20. $3\left(y^2 + 2\left(\frac{x+7}{2}\right)\right)$

21. $2y(x + x^2 - 2y)$

22. $(3x + y)(2x + 4y)$

Answers

1. 0

2. -5

3. 2

4. -4

5. 11

6. -11

7. -3

8. -56

9. 5

10. -5

11. 34

12. -19

13. 38; 45

14. 20; 41

15. -20; -5

16. -27; -45

17. 64

18. -24

19. -7

20. 36

21. 36

22. -32

Geometric figures can be reduced or enlarged. When this change happens, every length of the figure is reduced or enlarged equally (proportionally), and the measures of the corresponding angles stay the same.

The ratio of any two corresponding sides of the original and new figure is called a scale factor. The scale factor may be written as a percent or a fraction. It is common to write new figure measurements over their original figure measurements in a scale ratio, that is, $\frac{\text{NEW}}{\text{ORIGINAL}}$.

Example 1 using a 200% enlargement

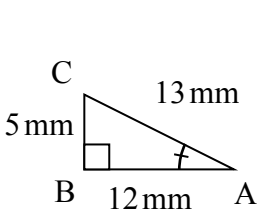

original triangle

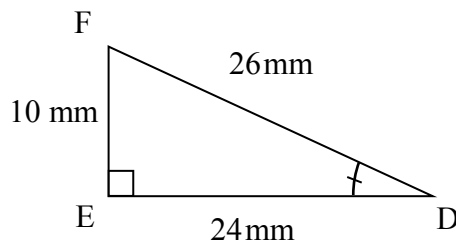

new triangle

Side length ratios:

$$\frac{DE}{AB} = \frac{24}{12} = \frac{2}{1}$$

$$\frac{FD}{CA} = \frac{26}{13} = \frac{2}{1}$$

$$\frac{FE}{CB} = \frac{10}{5} = \frac{2}{1}$$

The scale factor for length is 2 to 1.

Example 2

Figures A and B at right are similar. Assuming that Figure A is the original figure, find the scale factor and find the lengths of the missing sides of Figure B.

The scale factor is $\frac{3}{12} = \frac{1}{4}$. The lengths of the missing sides of Figure B are: $\frac{1}{4}(10) = 2.5$, $\frac{1}{4}(18) = 4.5$, and $\frac{1}{4}(20) = 5$.

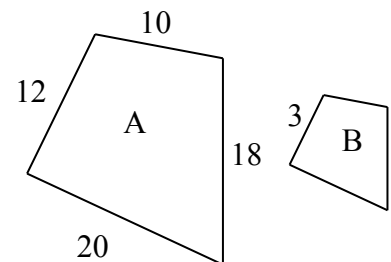

Problems

Determine the scale factor for each pair of similar figures in problems 1 through 4.

1.

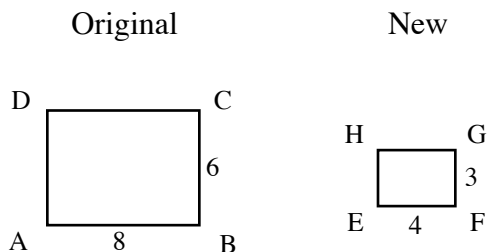

2.

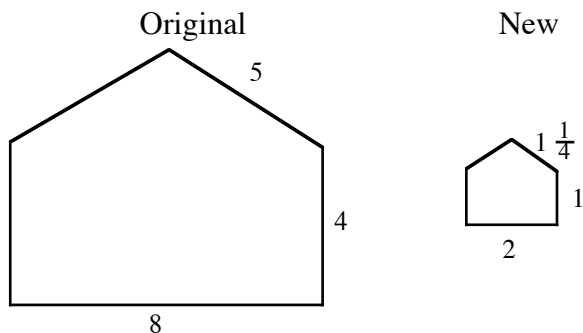

3.

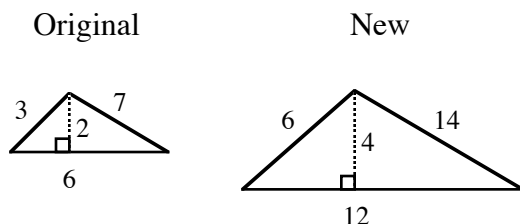

4.

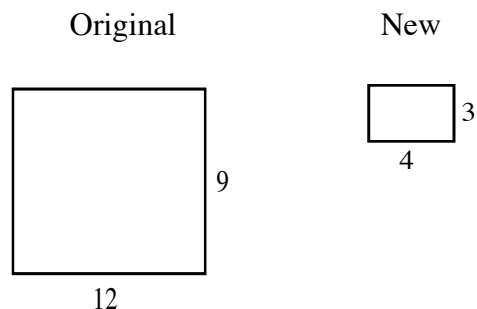

5. A triangle has sides 5, 12, and 13. The triangle was enlarged by a scale factor of 300%.
- What are the lengths of the sides of the new triangle?
 - What is the ratio of the perimeter of the new triangle to the perimeter of the original triangle?
6. A rectangle has a length of 60 cm and a width of 40 cm. The rectangle was reduced by a scale factor of 25%.
- What are the dimensions of the new rectangle?
 - What is the ratio of the perimeter of the new rectangle to the perimeter of the original rectangle?

Answers

1. $\frac{4}{8} = \frac{1}{2}$

2. $\frac{2}{8} = \frac{1}{4}$

3. $\frac{2}{1}$

4. $\frac{1}{3}$

5. a. 15, 36, 39 b. $\frac{3}{1}$

6. a. 15 cm and 10 cm b. $\frac{1}{4}$

MULTIPLYING FRACTIONS WITH AN AREA MODEL 5.1.1, 5.1.4, 5.2.2

Multiplication of fractions is reviewed using a rectangular area model. Lines that divide the rectangle to represent one fraction are drawn vertically, and the correct number of parts are shaded. Then lines that divide the rectangle to represent the second fraction are drawn horizontally and part of the shaded region is darkened to represent the product of the two fractions.

Example 1

$$\frac{1}{2} \cdot \frac{5}{8} \text{ (that is, } \frac{1}{2} \text{ of } \frac{5}{8} \text{)}$$

Step 1: Draw a generic rectangle and divide it into 8 pieces vertically. Lightly shade 5 of those pieces. Label it $\frac{5}{8}$.

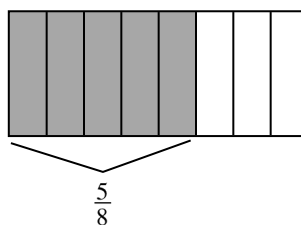

Step 2: Use a horizontal line and divide the generic rectangle in half. Darkly shade $\frac{1}{2}$ of $\frac{5}{8}$ and label it.

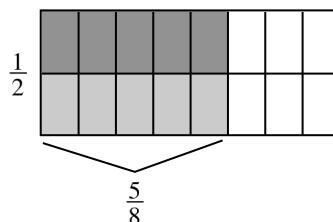

Step 3: Write a number sentence.

$$\frac{1}{2} \cdot \frac{5}{8} = \frac{5}{16}$$

The rule for multiplying fractions derived from the models above is to multiply the numerators, then multiply the denominators. Simplify the product when possible.

For additional information, see the Math Notes box in Lesson 5.1.4 of the *Core Connections, Course 1* text. For additional examples and practice, see the *Core Connections, Course 1* Checkpoint 7A materials.

Example 2

a. $\frac{2}{3} \cdot \frac{2}{7} \Rightarrow \frac{2 \cdot 2}{3 \cdot 7} \Rightarrow \frac{4}{21}$

b. $\frac{3}{4} \cdot \frac{6}{7} \Rightarrow \frac{3 \cdot 6}{4 \cdot 7} \Rightarrow \frac{18}{28} \Rightarrow \frac{9}{14}$

Problems

Draw an area model for each of the following multiplication problems and write the answer.

1. $\frac{1}{3} \cdot \frac{1}{6}$

2. $\frac{1}{4} \cdot \frac{3}{5}$

3. $\frac{2}{3} \cdot \frac{5}{9}$

Use the rule for multiplying fractions to find the answer for the following problems. Simplify when possible.

4. $\frac{1}{3} \cdot \frac{2}{5}$

5. $\frac{2}{3} \cdot \frac{2}{7}$

6. $\frac{3}{4} \cdot \frac{1}{5}$

7. $\frac{2}{5} \cdot \frac{2}{3}$

8. $\frac{2}{3} \cdot \frac{1}{4}$

9. $\frac{5}{6} \cdot \frac{2}{3}$

10. $\frac{4}{5} \cdot \frac{3}{4}$

11. $\frac{2}{15} \cdot \frac{1}{2}$

12. $\frac{3}{7} \cdot \frac{1}{2}$

13. $\frac{3}{8} \cdot \frac{4}{5}$

14. $\frac{2}{9} \cdot \frac{3}{5}$

15. $\frac{3}{10} \cdot \frac{5}{7}$

16. $\frac{5}{11} \cdot \frac{6}{7}$

17. $\frac{5}{6} \cdot \frac{3}{10}$

18. $\frac{10}{11} \cdot \frac{3}{5}$

19. $\frac{5}{12} \cdot \frac{3}{5}$

20. $\frac{7}{9} \cdot \frac{5}{14}$

Answers

1. $\frac{1}{18}$

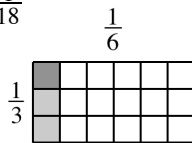

2. $\frac{3}{20}$

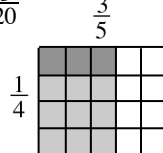

3. $\frac{10}{27}$

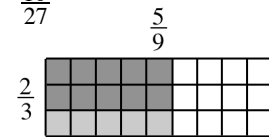

4. $\frac{2}{15}$

5. $\frac{4}{21}$

6. $\frac{3}{20}$

7. $\frac{4}{15}$

8. $\frac{2}{12} = \frac{1}{6}$

9. $\frac{10}{18} = \frac{5}{9}$

10. $\frac{12}{20} = \frac{3}{5}$

11. $\frac{2}{30} = \frac{1}{15}$

12. $\frac{3}{14}$

13. $\frac{12}{40} = \frac{3}{10}$

14. $\frac{6}{45} = \frac{2}{15}$

15. $\frac{15}{70} = \frac{3}{14}$

16. $\frac{30}{77}$

17. $\frac{15}{60} = \frac{1}{4}$

18. $\frac{30}{55} = \frac{6}{11}$

19. $\frac{15}{60} = \frac{1}{4}$

20. $\frac{35}{126} = \frac{5}{18}$

MULTIPLYING DECIMALS AND PERCENTS

Understanding how many places to move the decimal point in a decimal multiplication problem is connected to the multiplication of fractions and place value.

Computations involving calculating “a percent of a number” are simplified by changing the percent to a decimal.

Example 1

Multiply $(0.2) \cdot (0.3)$.

In fractions this means $\frac{2}{10} \cdot \frac{3}{10} \Rightarrow \frac{6}{100}$.

Knowing that the answer must be in the hundredths place tells you how many places to move the decimal point (to the left) without using the fractions.

(tenths)(tenths) = hundredths
Therefore move two places.

$$\begin{array}{r} 0.2 \\ \times 0.3 \\ \hline 0.06 \end{array}$$

Example 2

Multiply $(1.7) \cdot (0.03)$.

In fractions this means $\frac{17}{10} \cdot \frac{3}{100} \Rightarrow \frac{51}{1000}$.

Knowing that the answer must be in the thousandths place tells you how many places to move the decimal point (to the left) without using the fractions.

(tenths)(hundredths) = thousandths
Therefore move three places.

$$\begin{array}{r} 1.7 \\ \times 0.03 \\ \hline 0.051 \end{array}$$

Example 3

Calculate 17% of 32.5 without using a calculator.

Since $17\% = \frac{17}{100} = 0.17$,
 $17\% \text{ of } 32.5 \Rightarrow (0.17) \cdot (32.5)$
 $\Rightarrow 5.525$

$$\begin{array}{r} 32.5 \\ \times 0.17 \\ \hline 2275 \\ \underline{3250} \\ 5.525 \end{array}$$

Problems

Identify the number of places to the left to move the decimal point in the product. Do not compute the product.

- | | | |
|--------------------------|-------------------------|----------------------------|
| 1. $(0.3) \cdot (0.5)$ | 2. $(1.5) \cdot (0.12)$ | 3. $(1.23) \cdot (2.6)$ |
| 4. $(0.126) \cdot (3.4)$ | 5. $17 \cdot (32.016)$ | 6. $(4.32) \cdot (3.1416)$ |

Compute without using a calculator.

- | | | |
|-------------------------|---------------------------|--------------------------|
| 7. $(0.8) \cdot (0.03)$ | 8. $(3.2) \cdot (0.3)$ | 9. $(1.75) \cdot (0.09)$ |
| 10. $(4.5) \cdot (3.2)$ | 11. $(1.8) \cdot (0.032)$ | 12. $(7.89) \cdot (6.3)$ |
| 13. 8% of 540 | 14. 70% of 478 | 15. 37% of 4.7 |
| 16. 17% of 96 | 17. 15% of 4.75 | 18. 130% of 42 |

Answers

- | | | |
|-----------|------------|------------|
| 1. 2 | 2. 3 | 3. 3 |
| 4. 4 | 5. 3 | 6. 6 |
| 7. 0.024 | 8. 0.96 | 9. 0.1575 |
| 10. 14.4 | 11. 0.0576 | 12. 49.707 |
| 13. 43.2 | 14. 334.6 | 15. 1.739 |
| 16. 16.32 | 17. 0.7125 | 18. 54.6 |

Area is the number of non-overlapping square units needed to cover the interior region of a two-dimensional figure or the surface area of a three-dimensional figure. For example, area is the region that is covered by floor tile (two-dimensional) or paint on a box or a ball (three-dimensional).

For additional information about specific shapes, see the boxes below.

AREA OF A RECTANGLE

To find the area of a rectangle, follow the steps below.

1. Identify the base.
2. Identify the height.
3. Multiply the base times the height to find the area in square units: $A = bh$.

A square is a rectangle in which the base and height are of equal length. Find the area of a square by multiplying the base times itself: $A = b^2$.

Example

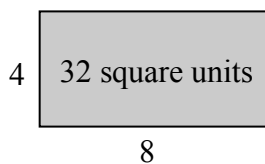

base = 8 units

height = 4 units

$$A = 8 \cdot 4 = 32 \text{ square units}$$

Problems

Find the areas of the rectangles (figures 1-8) and squares (figures 9-12) below.

1.

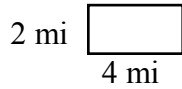

2.

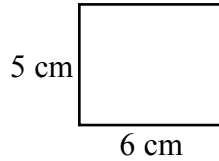

3.

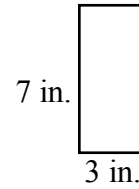

4.

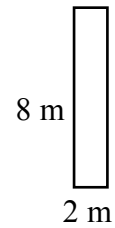

5.

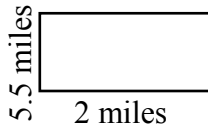

6.

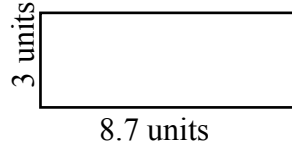

7.

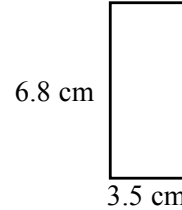

8.

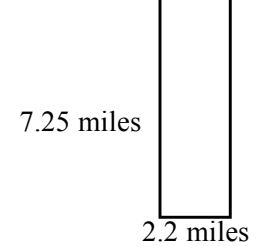

9.

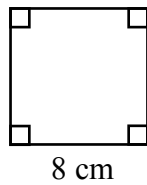

10.

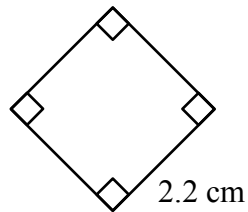

11.

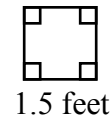

12.

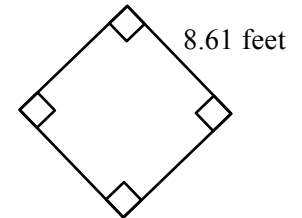

Answers

1. 8 sq. miles

2. 30 sq. cm

3. 21 sq. in.

4. 16 sq. m

5. 11 sq. miles

6. 26.1 sq. feet

7. 23.8 sq. cm

8. 15.95 sq. miles

9. 64 sq. cm

10. 4.84 sq. cm

11. 2.25 sq. feet

12. 73.96 sq. feet

AREA OF A PARALLELOGRAM

A parallelogram is easily changed to a rectangle by separating a triangle from one end of the parallelogram and moving it to the other end as shown in the three figures below. For additional information, see the Math Notes box in Lesson 5.3.3 of the *Core Connections, Course 1* text.

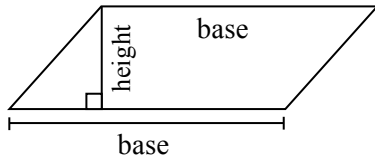

parallelogram
Step 1

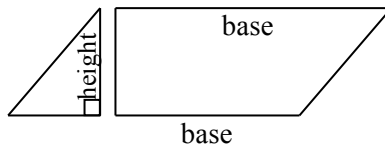

move triangle
Step 2

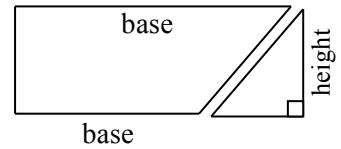

rectangle
Step 3

To find the area of a parallelogram, multiply the base times the height as you did with the rectangle: $A = bh$.

Example

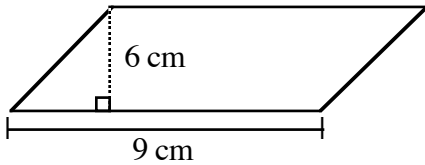

$$\text{base} = 9 \text{ cm}$$

$$\text{height} = 6 \text{ cm}$$

$$A = 9 \cdot 6 = 54 \text{ square cm}$$

Problems

Find the area of each parallelogram below.

1.

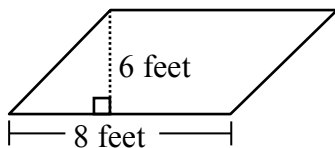

2.

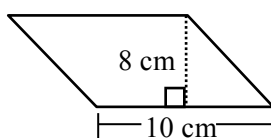

3.

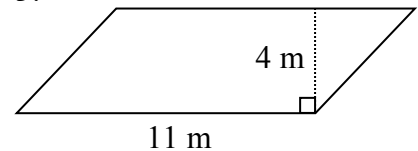

4.

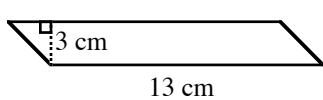

5.

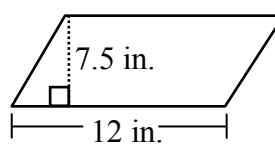

6.

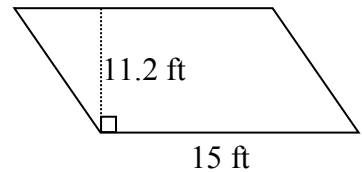

7.

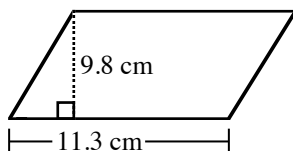

8.

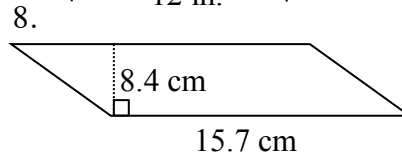

Answers

1. 48 sq. feet

2. 80 sq. cm

3. 44 sq. m

4. 39 sq. cm

5. 90 sq. in.

6. 168 sq. ft

7. 110.74 sq. cm

8. 131.88 sq. cm

AREA OF A TRIANGLE

The area of a triangle is equal to one-half the area of a parallelogram. This fact can easily be shown by cutting a parallelogram in half along a diagonal (see below). For additional information, see Math Notes box in Lesson 5.3.4 of the *Core Connections, Course 1* text.

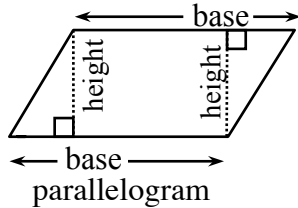

Step 1

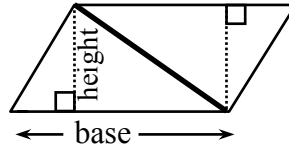

Step 2

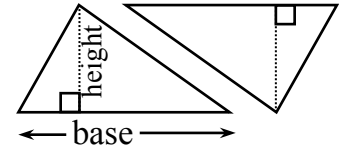

match triangles by cutting apart
or by folding

Step 3

As you match the triangles by either cutting the parallelogram apart or by folding along the diagonal, the result is two congruent (same size and shape) triangles. Thus, the area of a triangle has half the area of the parallelogram that can be created from two copies of the triangle.

To find the area of a triangle, follow the steps below.

1. Identify the base.
2. Identify the height.
3. Multiply the base times the height.
4. Divide the product of the base times the height by 2: $A = \frac{bh}{2}$ or $\frac{1}{2}bh$.

Example 1

base = 16 cm

height = 8 cm

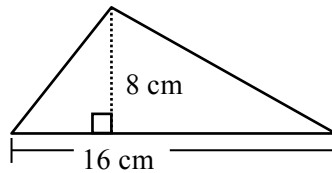

$$A = \frac{16 \cdot 8}{2} = \frac{128}{2} = 64 \text{ cm}^2$$

Example 2

base = 7 cm

height = 4 cm

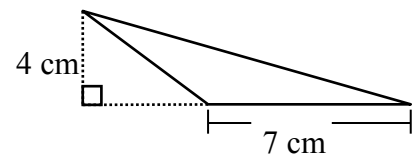

$$A = \frac{7 \cdot 4}{2} = \frac{28}{2} = 14 \text{ cm}^2$$

Problems

1.

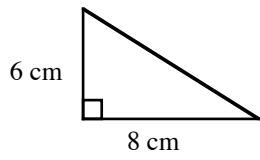

2.

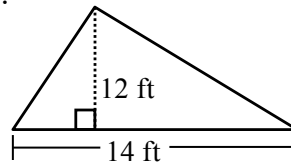

3.

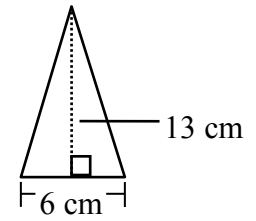

4.

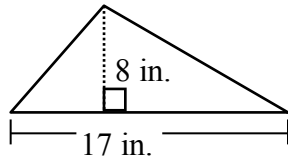

5.

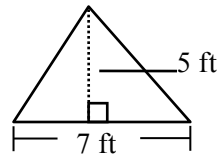

6.

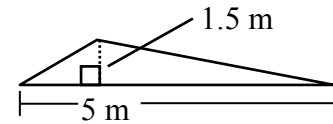

7.

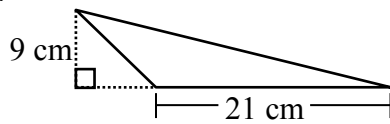

8.

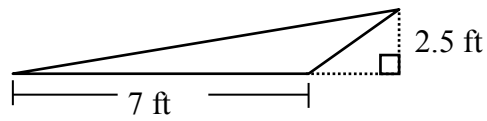

Answers

1. 24 sq. cm

2. 84 sq. ft

3. 39 sq. cm

4. 68 sq. in.

5. 17.5 sq. ft

6. 3.75 sq. m

7. 94.5 sq. cm

8. 8.75 sq. ft

AREA OF A TRAPEZOID

A trapezoid is another shape that can be transformed into a parallelogram. Change a trapezoid into a parallelogram by following the three steps below.

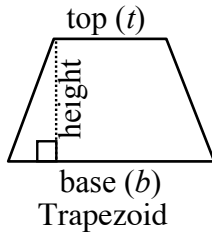

Step 1

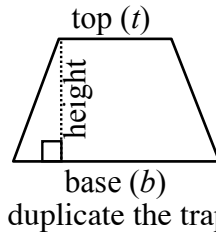

Step 2

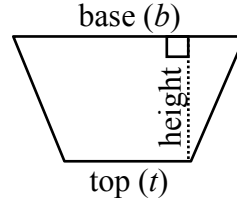

Step 3

To find the area of a trapezoid, multiply the base of the large parallelogram in Step 3 (base and top) times the height and then take half of the total area. Remember to add the lengths of the base and the top of the trapezoid before multiplying by the height. Note that some texts call the top length the upper base and the base the lower base.

$$A = \frac{1}{2}(b + t)h \quad \text{or} \quad A = \frac{b+t}{2} \cdot h$$

For additional information, see the Math Notes box in Lesson 6.1.1 of the *Core Connections, Course 1* text.

Example

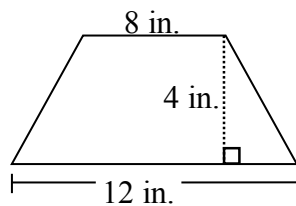

$$\text{top} = 8 \text{ in.}$$

$$\text{base} = 12 \text{ in.}$$

$$\text{height} = 4 \text{ in.}$$

$$A = \frac{8+12}{2} \cdot 4 = \frac{20}{2} \cdot 4 = 10 \cdot 4 = 40 \text{ in.}^2$$

Problems

Find the areas of the trapezoids below.

1.

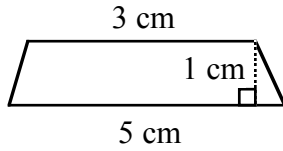

2.

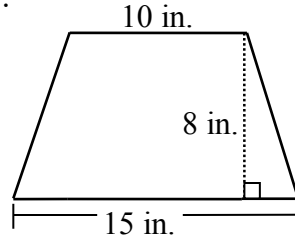

3.

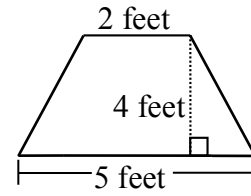

4.

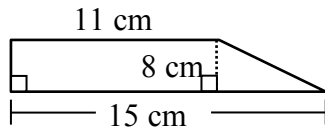

5.

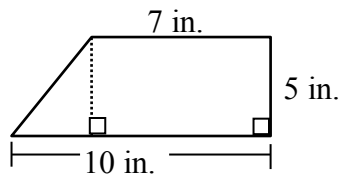

6.

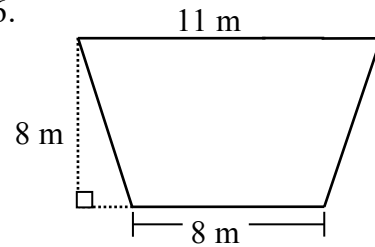

7.

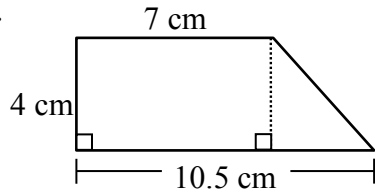

8.

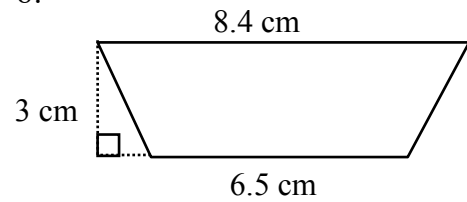

Answers

1. 4 sq. cm

2. 100 sq. in.

3. 14 sq. feet

4. 104 sq. cm

5. 42.5 sq. in.

6. 76 sq. m

7. 35 sq. cm

8. 22.35 sq. cm.

Division by fractions introduces three methods to help students understand how dividing by fractions works. In general, think of division for a problem like $8 \div 2$ as, “In 8, how many groups of 2 are there?” Similarly, $\frac{1}{2} \div \frac{1}{4}$ means, “In $\frac{1}{2}$, how many fourths are there?”

For more information, see the Math Notes boxes in Lessons 7.2.2 and 7.2.4 of the *Core Connections, Course 1* text. For additional examples and practice, see the *Core Connections, Course 1* Checkpoint 8B materials. The first two examples show how to divide fractions using a diagram.

Example 1

Use the rectangular model to divide: $\frac{1}{2} \div \frac{1}{4}$.

Step 1: Using the rectangle, we first divide it into 2 equal pieces. Each piece represents $\frac{1}{2}$. Shade $\frac{1}{2}$ of it.

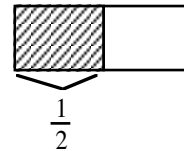

Step 2: Then divide the *original* rectangle into four equal pieces. Each section represents $\frac{1}{4}$. In the shaded section, $\frac{1}{2}$, there are 2 fourths.

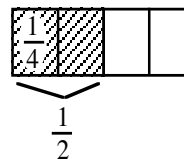

Step 3: Write the equation.

$$\frac{1}{2} \div \frac{1}{4} = 2$$

Example 2

In $\frac{3}{4}$, how many $\frac{1}{2}$'s are there?

That is, $\frac{3}{4} \div \frac{1}{2} = ?$



Start with $\frac{3}{4}$.

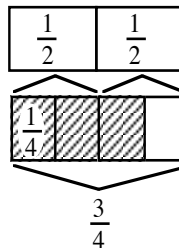

In $\frac{3}{4}$ there is one full $\frac{1}{2}$ shaded and half of another one (that is half of one-half).

So: $\frac{3}{4} \div \frac{1}{2} = 1\frac{1}{2}$
(one and one-half halves)

Problems

Use the rectangular model to divide.

1. $1\frac{1}{3} \div \frac{1}{6}$ 2. $\frac{3}{2} \div \frac{3}{4}$ 3. $1 \div \frac{1}{4}$ 4. $1\frac{1}{4} \div \frac{1}{2}$ 5. $2\frac{2}{3} \div \frac{1}{9}$

Answers

1. 8



8 sixths

2. 2

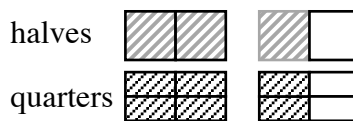

2 three fourths

3. 4



4 fourths

4. $2\frac{1}{2}$

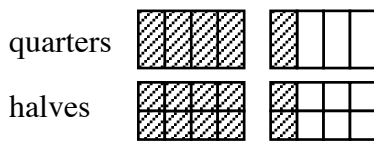

$2\frac{1}{2}$ halves

5. 24

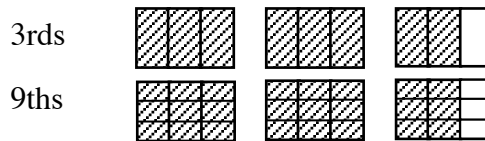

24 ninths

The next two examples use common denominators to divide by a fraction. Express both fractions with a common denominator, then divide the first numerator by the second.

Example 3

$$\frac{4}{5} \div \frac{2}{3} \Rightarrow \frac{12}{15} \div \frac{10}{15} \Rightarrow \frac{12}{10} \Rightarrow \frac{6}{5} \text{ or } 1\frac{1}{5}$$

Example 4

$$1\frac{1}{3} \div \frac{1}{6} \Rightarrow \frac{4}{3} \div \frac{1}{6} \Rightarrow \frac{8}{6} \div \frac{1}{6} \Rightarrow \frac{8}{1} \text{ or } 8$$

One more way to divide fractions is to use the Giant One from previous work with fractions to create a “Super Giant One.” To use a Super Giant One, write the division problem in fraction form, with a fraction in both the numerator and the denominator. Use the reciprocal of the denominator for the numerator and the denominator in the Super Giant One, multiply the fractions as usual, and simplify the resulting fraction when possible.

Example 5

$$\frac{\frac{1}{2}}{\frac{1}{4}} = \frac{\frac{4}{1}}{\frac{4}{1}} = \frac{4}{1} = 4 = 2$$

Example 6

$$\frac{\frac{3}{4}}{\frac{1}{6}} = \frac{\frac{6}{1}}{\frac{6}{1}} = \frac{18}{1} = \frac{9}{2} = 4 \frac{1}{2}$$

Example 7

$$1 \frac{1}{3} = \frac{4}{3} \cdot \frac{\frac{2}{3}}{\frac{2}{3}} = \frac{8}{9} = \frac{8}{9}$$

Example 8

$$\frac{2}{3} \div \frac{3}{5} \Rightarrow \frac{10}{15} \div \frac{9}{15} \Rightarrow \frac{10}{9}$$

Compared to:

$$\frac{\frac{2}{3}}{\frac{3}{5}} = \frac{\frac{5}{3}}{\frac{5}{3}} = \frac{10}{9} = 1 \frac{1}{9}$$

Problems

Complete the division problems below. Use any method.

1. $\frac{3}{7} \div \frac{1}{8}$
2. $1\frac{3}{7} \div \frac{1}{2}$
3. $\frac{4}{7} \div \frac{1}{3}$
4. $1\frac{4}{7} \div \frac{1}{3}$
5. $\frac{6}{7} \div \frac{5}{8}$
6. $\frac{3}{10} \div \frac{5}{7}$
7. $2\frac{1}{3} \div \frac{5}{8}$
8. $7 \div \frac{1}{3}$
9. $1\frac{1}{3} \div \frac{2}{5}$
10. $2\frac{2}{3} \div \frac{3}{4}$
11. $3\frac{1}{3} \div \frac{5}{6}$
12. $1\frac{1}{2} \div \frac{1}{2}$
13. $\frac{5}{8} \div 1\frac{1}{4}$
14. $10\frac{1}{3} \div \frac{1}{6}$
15. $\frac{3}{5} \div 6$

Answers

1. $3\frac{3}{7}$
2. $2\frac{6}{7}$
3. $1\frac{5}{7}$
4. $4\frac{5}{7}$
5. $1\frac{13}{35}$
6. $\frac{21}{50}$
7. $3\frac{11}{15}$
8. 21
9. $3\frac{1}{3}$
10. $3\frac{5}{9}$
11. 4
12. 3
13. $\frac{1}{2}$
14. 62
15. $\frac{1}{10}$

When students are first given expressions like $3 + 4 \cdot 2$, some students think the answer is 14 and some think the answer is 11. This is why mathematicians decided on a method to simplify an expression that uses more than one operation so that everyone can agree on the answer.

There is a set of rules to follow that provides a consistent way for everyone to evaluate expressions. These rules, called the Order of Operations, must be followed in order to arrive at a correct answer. As indicated by the name, these rules state the order in which the mathematical operations are to be completed.

For additional information, see the Math Notes box in Lesson 6.2.1 of the *Core Connections, Course 1* text.

The first step is to organize the numerical expression into parts called terms, which are single numbers or products of numbers. A numerical expression is made up of a sum or difference of terms.

Examples of numerical terms are: 4, $3(6)$, $6(9 - 4)$, $2 \cdot 3^2$, $3(5 + 2^3)$, and $\frac{16-4}{6}$.

For the problem above, $3 + 4 \cdot 2$, the terms are circled at right. $(3) + (4 \cdot 2)$

Each term is simplified separately, giving $3 + 8$. Then the terms are added: $3 + 8 = 11$. Thus, $3 + 4 \cdot 2 = 11$.

Example 1

$$2 \cdot 3^2 + 3(6 - 3) + 10$$

To evaluate an expression:

- Circle each term in the expression.
- Simplify each term until it is one number by:
 - Simplifying the expressions within the parentheses.
 - Evaluating each exponential part (e.g., 3^2).
 - Multiplying and dividing from left to right.
- Finally, combine terms by adding or subtracting from left to right.

$$\begin{aligned} & (2 \cdot 3^2) + (3(6 - 3)) + (10) \\ & (2 \cdot 3^2) + (3(3)) + (10) \\ & (2 \cdot 9) + (3(3)) + (10) \\ & (18) + (9) + (10) \\ & 27 + 10 \\ & 37 \end{aligned}$$

Example 2

- Circle the terms.
- Simplify inside the parentheses.
- Simplify the exponents.
- Multiply and divide from left to right.

Finally, add and subtract from left to right.

$$5 - 8 \div 2^2 + 6(5 + 4) - 5^2$$

- $(5) - (8 \div 2^2) + (6(5 + 4)) - (5^2)$
- $(5) - (8 \div 2^2) + (6(9)) - (5^2)$
- $(5) - (8 \div 4) + (6(9)) - (25)$
- $5 - 2 + 54 - 25$

32

Example 3

- Circle the terms.
- Multiply and divide left to right, including exponents.

Add or subtract from left to right.

$$20 + \frac{5+7}{3} - 4^2 + 12 \div 4$$

- $(20) + (\frac{5+7}{3}) - (4^2) + (12 \div 4)$
- $20 + 4 - 16 + 3$

11

Problems

Circle the terms, then simplify each expression.

- $5 \cdot 3 + 4$
- $10 \div 5 + 3$
- $2(9 - 4) \cdot 7$
- $6(7 + 3) + 8 \div 2$
- $15 \div 3 + 7(8 + 1) - 6$
- $\frac{9}{3} + 5 \cdot 3^2 - 2(14 - 5)$
- $\frac{20}{6+4} + 7 \cdot 2 \div 2$
- $\frac{5+30}{7} + 6^2 - 18 \div 9$
- $2^3 + 8 - 16 \div 8 \cdot 2$
- $25 - 5^2 + 9 - 3^2$
- $5(17 - 7) + 4 \cdot 3 - 8$
- $(5 - 2)^2 + (9 + 1)^2$
- $4^2 + 9(2) \div 6 + (6 - 1)^2$
- $\frac{18}{3^2} + \frac{5 \cdot 3}{5}$
- $3(7 - 2)^2 + 8 \div 4 - 6 \cdot 5$
- $14 \div 2 + 6 \cdot 8 \div 2 - (9 - 3)^2$
- $\frac{27}{3} + 18 - 9 \div 3 - (3 + 4)^2$
- $26 \cdot 2 \div 4 - (6 + 4)^2 + 3(5 - 2)^3$
- $(\frac{42+3}{5})^2 + 3^2 - (5 \cdot 2)^2$

Answers

- | | | | | |
|--------|---------|--------|---------|--------|
| 1. 19 | 2. 5 | 3. 70 | 4. 64 | 5. 62 |
| 6. 30 | 7. 9 | 8. 39 | 9. 12 | 10. 0 |
| 11. 54 | 12. 109 | 13. 44 | 14. 5 | 15. 47 |
| 16. -5 | 17. -25 | 18. -6 | 19. -10 | |

Algebraic expressions can be represented by the perimeters of algebra tiles (rectangles and squares) and combinations of algebra tiles. The dimensions of each tile are shown along its sides and the tile is named by its area as shown on the tile itself in the figures at right. When using the tiles, perimeter is the distance around the exterior of a figure. For additional information, see the Math Notes box in Lesson 6.2.4 of the *Core Connections, Course 1* text.

Example 1

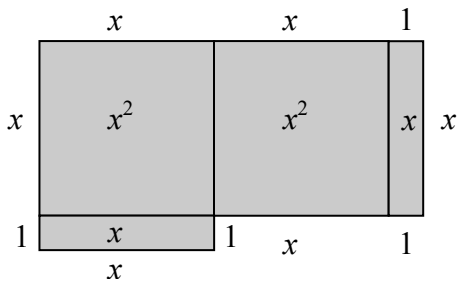

$P = 6x + 4$ units

Example 2

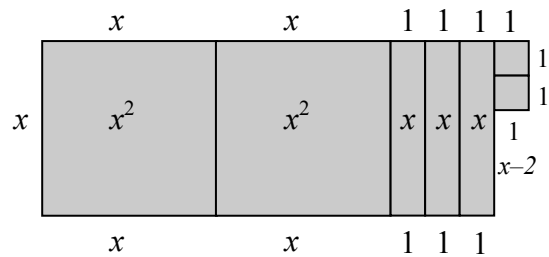

$P = 6x + 8$ units

Problems

Determine the perimeter of each figure.

1.

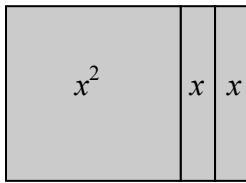

2.

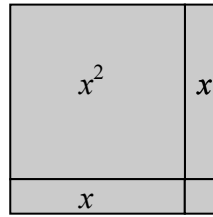

3.

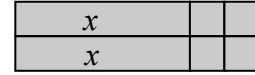

4.

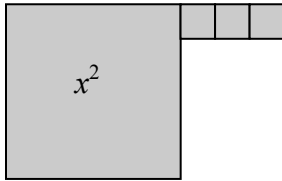

5.

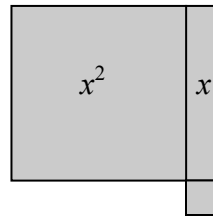

6.

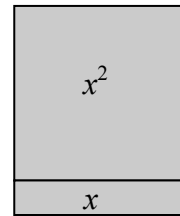

7.

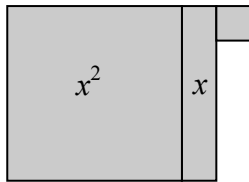

8.

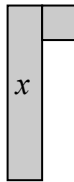

Answers

1. $4x + 4$ un.

2. $4x + 4$ un.

3. $2x + 8$ un.

4. $4x + 6$ un.

5. $4x + 4$ un.

6. $4x + 2$ un.

7. $4x + 4$ un.

8. $2x + 4$ un.

Algebraic expressions can also be simplified by combining (adding or subtracting) terms that have the same variable(s) raised to the same powers, into one term. The skill of combining like terms is necessary for solving equations. For additional information, see the Math Notes box in Lesson 6.2.4 of the *Core Connections, Course 1* text.

Example 1

Combine like terms to simplify the expression $3x + 5x + 7x$.

All these terms have x as the variable, so they are combined into one term, $15x$.

Example 2

Simplify the expression $3x + 12 + 7x + 5$.

The terms with x can be combined. The terms without variables (the constants) can also be combined.

$$3x + 12 + 7x + 5$$

$$3x + 7x + 12 + 5$$

$$10x + 17$$

Note that in the simplified form the term with the variable is listed before the constant term.

Example 3

Simplify the expression $5x + 4x^2 + 10 + 2x^2 + 2x - 6 + x - 1$.

$$5x + 4x^2 + 10 + 2x^2 + 2x - 6 + x - 1$$

$$4x^2 + 2x^2 + 5x + 2x + x + 10 - 6 - 1$$

$$6x^2 + 8x + 3$$

Note that terms with the same variable but with different exponents are not combined and are listed in order of decreasing power of the variable, in simplified form, with the constant term last.

Example 4

The algebra tiles, as shown in the *Algebra Tiles and Perimeter* section, are used to model how to combine like terms.

The large square represents x^2 , the rectangle represents x , and the small square represents one. We can only combine tiles that are alike: large squares with large squares, rectangles with rectangles, and small squares with small squares. If we want to combine:
 $2x^2 + 3x + 4$ and $3x^2 + 5x + 7$, visualize the tiles to help combine the like terms:

$$\begin{aligned} & 2x^2 \text{ (2 large squares)} + 3x \text{ (3 rectangles)} + 4 \text{ (4 small squares)} \\ & + 3x^2 \text{ (3 large squares)} + 5x \text{ (5 rectangles)} + 7 \text{ (7 small squares)} \end{aligned}$$

The combination of the two sets of tiles, written algebraically, is: $5x^2 + 8x + 11$.

Example 5

Sometimes it is helpful to take an expression that is written horizontally, circle the terms with their signs, and rewrite *like* terms in vertical columns before you combine them:

$$\begin{array}{r} (2x^2 - 5x + 6) + (3x^2 + 4x - 9) \\ \textcircled{2x^2} - \textcircled{5x} + \textcircled{6} + \textcircled{3x^2} + \textcircled{4x} - \textcircled{9} \\ 2x^2 - 5x + 6 \\ + 3x^2 + 4x - 9 \\ \hline 5x^2 - x - 3 \end{array}$$

This procedure may make it easier to identify the terms as well as the sign of each term.

Problems

Combine the following sets of terms.

- $(2x^2 + 6x + 10) + (4x^2 + 2x + 3)$
- $(3x^2 + x + 4) + (x^2 + 4x + 7)$
- $(8x^2 + 3) + (4x^2 + 5x + 4)$
- $(4x^2 + 6x + 5) - (3x^2 + 2x + 4)$
- $(4x^2 - 7x + 3) + (2x^2 - 2x - 5)$
- $(3x^2 - 7x) - (x^2 + 3x - 9)$
- $(5x + 6) + (-5x^2 + 6x - 2)$
- $2x^2 + 3x + x^2 + 4x - 3x^2 + 2$
- $3c^2 + 4c + 7x - 12 + (-4c^2) + 9 - 6x$
- $2a^2 + 3a^3 - 4a^2 + 6a + 12 - 4a + 2$

Answers

- $6x^2 + 8x + 13$
- $4x^2 + 5x + 11$
- $12x^2 + 5x + 7$
- $x^2 + 4x + 1$
- $6x^2 - 9x - 2$
- $2x^2 - 10x + 9$
- $-5x^2 + 11x + 4$
- $7x + 2$
- $-c^2 + 4c + x - 3$
- $3a^3 - 2a^2 + 2a + 14$

Rate of change is a ratio that describes how one quantity is changing with respect to another. Unit rate is a rate that compares the change in one quantity to a one-unit change in another quantity. Some examples of rates are miles per hour and price per pound. If 16 ounces of flour cost \$0.80 then the unit cost, that is the cost per one ounce, is $\frac{\$0.80}{16} = \0.05 .

For additional information see the Math Notes box in Lesson 7.1.3 of the *Core Connections, Course 1* text.

Example 1

A rice recipe uses 6 cups of rice for 15 people. At the same rate, how much rice is needed for 40 people?

The rate is: $\frac{6 \text{ cups}}{15 \text{ people}}$ so we need to solve $\frac{6}{15} = \frac{x}{40}$.

The multiplier needed for the Giant One is $\frac{40}{15}$ or $2\frac{2}{3}$.

Using that multiplier yields $\frac{6}{15} \cdot \frac{2\frac{2}{3}}{2\frac{2}{3}} = \frac{16}{40}$ so 16 cups of rice is needed.

Note that the equation $\frac{6}{15} = \frac{x}{40}$ can also be solved using proportions.

Example 2

Arrange these rates from least to greatest:

30 miles in 25 minutes

60 miles in one hour

70 miles in $1\frac{2}{3}$ hr

Changing each rate to a common denominator of 60 minutes yields:

$$\frac{30 \text{ mi}}{25 \text{ min}} = \frac{x}{60} \Rightarrow \frac{30}{25} \cdot \frac{2.4}{2.4} \Rightarrow \frac{72 \text{ mi}}{60 \text{ min}}$$

$$\frac{60 \text{ mi}}{1 \text{ hr}} = \frac{60 \text{ mi}}{60 \text{ min}}$$

$$\frac{70 \text{ mi}}{1\frac{2}{3} \text{ hr}} = \frac{70 \text{ mi}}{100 \text{ min}} = \frac{x}{60} \Rightarrow \frac{70}{100} \cdot \frac{0.6}{0.6} = \frac{42 \text{ mi}}{60 \text{ min}}$$

So the order from least to greatest is: 70 miles in $1\frac{2}{3}$ hr < 60 miles in one hour < 30 miles in 25 minutes. Note that by using 60 minutes (one hour) for the common unit to compare speeds, we can express each rate as a unit rate: 42 mph, 60 mph, and 72 mph.

Example 3

A train in France traveled 932 miles in 5 hours. What is the unit rate in miles per hour?

Unit rate means the denominator needs to be 1 hour so: $\frac{932 \text{ mi}}{5 \text{ hr}} = \frac{x}{1 \text{ hr}}$. Solving by using a Giant One of $\frac{0.2}{0.2}$ or simple division yields $x = 186.4$ miles per hour.

Problems

Solve each rate problem below. Explain your method.

1. Balvina knows that 6 cups of rice will make enough Spanish rice to feed 15 people. She needs to know how many cups of rice are needed to feed 135 people.
2. Elaine can plant 6 flowers in 15 minutes. How long will it take her to plant 30 flowers at the same rate?
3. A plane travels 3400 miles in 8 hours. How far would it travel in 6 hours at this rate?
4. Shane rode his bike for 2 hours and traveled 12 miles. At this rate, how long would it take him to travel 22 miles?
5. Selina's car used 15.6 gallons of gas to go 234 miles. At this rate, how many gallons would it take her to go 480 miles?
6. Arrange these readers from fastest to slowest: Abel read 50 pages in 45 minutes, Brian read 90 pages in 75 minutes, and Charlie read 175 pages in 2 hours.
7. Arrange these lunch buyers from greatest to least assuming they buy lunch 5 days per week: Alice spends \$3 per day, Betty spends \$25 every two weeks, and Cindy spends \$75 per month.
8. A train in Japan can travel 813.5 miles in 5 hours. Find the unit rate in miles per hour.
9. An ice skater covered 1500 meters in 106 seconds. Find his unit rate in meters per second.
10. A cellular company offers a price of \$19.95 for 200 minutes. Find the unit rate in cost per minute.
11. A car traveled 200 miles on 8 gallons of gas. Find the unit rate of miles per gallon and the unit rate of gallons per mile.
12. Lee's paper clip chain is 32 feet long. He is going to add paper clips continually for the next eight hours. At the end of eight hours the chain is 80 feet long. Find the unit rate of growth in feet per hour.

Answers

- | | | | |
|------------------------|---------------------------------|--------------------------------|----------------------|
| 1. 54 cups | 2. 75 min | 3. 2550 miles | 4. $3\frac{2}{3}$ hr |
| 5. 32 gallons | 6. C, B, A | 7. C, A, B | 8. 162.7 mi/hr |
| 9. ≈ 14.15 m/s | 10. $\approx \$0.10/\text{min}$ | 11. 25 m/g; $\frac{1}{25}$ g/m | 12. 6 ft/hr |

ARITHMETIC OPERATIONS WITH DECIMALS

ADDING AND SUBTRACTING DECIMALS: Write the problem in column form with the decimal points in a vertical column. Write in zeros so that all decimal parts of the number have the same number of digits. Add or subtract as with whole numbers. Place the decimal point in the answer aligned with those above.

MULTIPLYING DECIMALS: Multiply as with whole numbers. In the product, the number of decimal places is equal to the total number of decimal places in the factors (numbers you multiplied). Sometimes zeros need to be added to place the decimal point.

DIVIDING DECIMALS: When dividing a decimal by a whole number, place the decimal point in the answer space directly above the decimal point in the number being divided. Divide as with whole numbers. Sometimes it is necessary to add zeros to the number being divided to complete the division.

When dividing decimals or whole numbers by a decimal, the divisor must be multiplied by a power of ten to make it a whole number. The dividend must be multiplied by the same power of ten. Then divide following the same rules for division by a whole number.

For additional information, see the Math Notes box in Lesson 5.2.2 of the *Core Connections, Course 1* text. For additional examples and practice, see the *Core Connections, Course 1* Checkpoint 2, Checkpoint 7A, and Checkpoint 8B materials.

Example 1

Add 47.37, 28.9, 14.56, and 7.8.

$$\begin{array}{r} 47.37 \\ 28.90 \\ 14.56 \\ + 7.80 \\ \hline 98.63 \end{array}$$

Example 2

Subtract 198.76 from 473.2.

$$\begin{array}{r} 473.20 \\ - 198.76 \\ \hline 274.44 \end{array}$$

Example 3

Multiply 27.32 by 14.53.

$$\begin{array}{r} 27.32 \text{ (2 decimal places)} \\ \times 14.53 \text{ (2 decimal places)} \\ \hline 8196 \\ 13660 \\ 10928 \\ 2732 \\ \hline 396.9596 \text{ (4 decimal places)} \end{array}$$

Example 4

Multiply 0.37 by 0.0004.

$$\begin{array}{r} 0.37 \text{ (2 decimal places)} \\ \times 0.0004 \text{ (4 decimal places)} \\ \hline 0.000148 \text{ (6 decimal places)} \end{array}$$

Example 5

Divide 32.4 by 8.

$$\begin{array}{r} 4.05 \\ 8 \overline{) 32.40} \\ \underline{32} \\ 0 \\ \underline{40} \\ 0 \end{array}$$

Example 6

Divide 27.42 by 1.2. First multiply each number by 10^1 or 10.

$$1.2 \overline{) 27.42} \Rightarrow 12 \overline{) 274.2} \Rightarrow 12 \overline{) 274.20}$$

$$\begin{array}{r} 22.85 \\ 12 \overline{) 274.20} \\ \underline{24} \\ 34 \\ \underline{24} \\ 102 \\ \underline{96} \\ 60 \\ \underline{60} \\ 0 \end{array}$$

Problems

1. $4.7 + 7.9$
2. $3.93 + 2.82$
3. $38.72 + 6.7$
4. $58.3 + 72.84$
5. $4.73 + 692$
6. $428 + 7.392$
7. $42.1083 + 14.73$
8. $9.87 + 87.47936$
9. $9.999 + 0.001$
10. $0.0001 + 99.9999$
11. $0.0137 + 1.78$
12. $2.037 + 0.09387$
13. $15.3 + 72.894$
14. $47.9 + 68.073$
15. $289.307 + 15.938$
16. $476.384 + 27.847$
17. $15.38 + 27.4 + 9.076$
18. $48.32 + 284.3 + 4.638$
19. $278.63 + 47.0432 + 21.6$
20. $347.68 + 28.00476 + 84.3$
21. $8.73 - 4.6$
22. $9.38 - 7.5$
23. $8.312 - 6.98$
24. $7.045 - 3.76$
25. $6.304 - 3.68$
26. $8.021 - 4.37$
27. $14 - 7.431$
28. $23 - 15.37$
29. $10 - 4.652$
30. $18 - 9.043$
31. $0.832 - 0.47$
32. $0.647 - 0.39$
33. $1.34 - 0.0538$
34. $2.07 - 0.523$
35. $4.2 - 1.764$
36. $3.8 - 2.406$
37. $38.42 - 32.605$
38. $47.13 - 42.703$
39. $15.368 + 14.4 - 18.5376$
40. $87.43 - 15.687 - 28.0363$
41. $7.34 \cdot 6.4$
42. $3.71 \cdot 4.03$
43. $0.08 \cdot 4.7$
44. $0.04 \cdot 3.75$
45. $41.6 \cdot 0.302$
46. $9.4 \cdot 0.0053$
47. $3.07 \cdot 5.4$
48. $4.023 \cdot 3.02$
49. $0.004 \cdot 0.005$
50. $0.007 \cdot 0.0004$
51. $0.235 \cdot 0.43$
52. $4.32 \cdot 0.0072$
53. $0.0006 \cdot 0.00013$
54. $0.0005 \cdot 0.00026$
55. $8.38 \cdot 0.0001$
56. $47.63 \cdot 0.000001$
57. $0.078 \cdot 3.1$
58. $0.043 \cdot 4.2$
59. $350 \cdot 0.004$
60. $421 \cdot 0.00005$

Divide. Round answers to the hundredth, if necessary.

61. $14.3 \div 8$

62. $18.32 \div 5$

63. $147.3 \div 6$

64. $46.36 \div 12$

65. $100.32 \div 24$

66. $132.7 \div 28$

67. $47.3 \div 0.002$

68. $53.6 \div 0.004$

69. $500 \div 0.004$

70. $420 \div 0.05$

71. $1.32 \div 0.032$

72. $3.486 \div 0.012$

73. $46.3 \div 0.011$

74. $53.7 \div 0.023$

75. $25.46 \div 5.05$

76. $26.35 \div 2.2$

77. $6.042 \div 0.006$

78. $7.035 \div 0.005$

79. $207.3 \div 4.4$

80. $306.4 \div 3.2$

Answers

1. 12.6

2. 6.75

3. 45.42

4. 131.14

5. 696.73

6. 435.392

7. 56.8383

8. 97.34936

9. 10.000

10. 100.0000

11. 1.7937

12. 2.13087

13. 88.194

14. 115.973

15. 305.245

16. 504.231

17. 51.856

18. 337.258

19. 347.2732

20. 459.98476

21. 4.13

22. 1.88

23. 1.332

24. 3.285

25. 2.624

26. 3.651

27. 6.569

28. 7.63

29. 5.348

30. 8.957

31. 0.362

32. 0.257

33. 1.2862

34. 1.547

35. 2.436

36. 1.394

37. 5.815

38. 4.427

39. 11.2304

40. 43.7067

41. 46.976

42. 14.9513

43. 0.376

44. 0.15

45. 12.5632

46. 0.04982

47. 16.578

48. 12.14946

49. 0.000020

50. 0.0000028

51. 0.10105

52. 0.031104

53. 0.000000078

54. 0.000000130

55. 0.000838

56. 0.0004763

57. 0.2418

58. 0.1806

59. 1.4

60. 0.02105

61. 1.7875 or 1.79

62. 3.664 or 3.66

63. 24.55

64. $3.86\bar{3}$ or 3.86

65. 4.18

66. 4.74

67. 23,650

68. 13,400

69. 125,000

70. 8400

71. 41.25

72. 29.05

73. 4209.09

74. 2334.78

75. 5.04

76. 11.98

77. 1007

78. 1407

79. 47.11

80. 95.75

GRAPHING INEQUALITIES

The solutions to an equation can be represented as a point (or points) on the number line. If the expression comparison mat has a range of solutions, the solution is expressed as an inequality represented by a ray or segment with solid or open endpoints. Solid endpoints indicate that the endpoint is included in the solution (\leq or \geq), while the open dot indicates that it is not part of the solution ($<$ or $>$).

For additional information, see the Math Notes box in Lesson 7.3.4 of the *Core Connections, Course 1* text.

Example 1

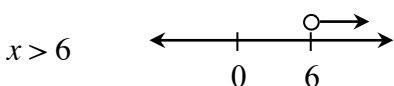

Example 2

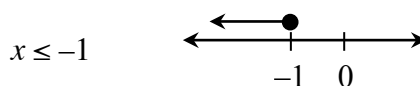

Example 3

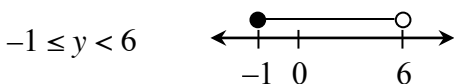

Example 4

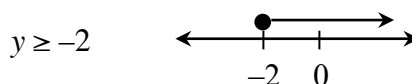

Problems

Graph each inequality on a number line.

- | | | |
|-----------------------|------------------|--------------------|
| 1. $m < 2$ | 2. $x \leq -1$ | 3. $y \geq 3$ |
| 4. $-1 \leq x \leq 3$ | 5. $-6 < x < -2$ | 6. $-1 < x \leq 2$ |
| 7. $m > -9$ | 8. $x \neq 1$ | 9. $x \leq 3$ |

Answers

- | | | |
|----|----|----|
| 1. | 2. | 3. |
| 4. | 5. | 6. |
| 7. | 8. | 9. |

SOLVING INEQUALITIES

To solve an inequality, examine both of the expressions on an expression comparison mat. Use the result as a dividing point on the number line. Then test a value from each side of the dividing point on the number line in the inequality. If the test number is true, then that part of the number line is part of the solution. In addition, if the inequality is \geq or \leq , then the dividing point is part of the solution and is indicated by a solid dot. If the inequality is $>$ or $<$, then the dividing point is not part of the solution, indicated by an open dot.

Example 1

$$9 \geq m + 2$$

Solve the equation: $9 = m + 2$
 $7 = m$

Draw a number line. Put a solid dot at 7.

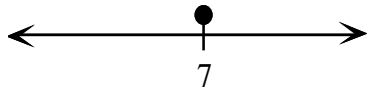

Test a number on each side of 7 in the original inequality. We use 10 and 0.

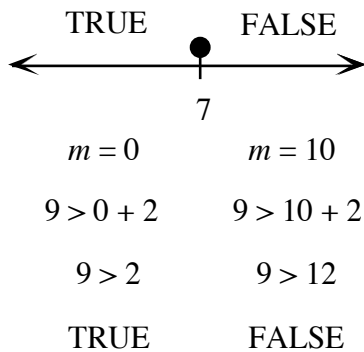

The solution is $m \leq 7$.

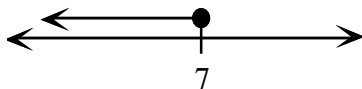

Example 2

$$-2x - 3 < x + 6$$

Solve the equation: $-2x - 3 = x + 6$
 $-2x = x + 9$
 $-3x = 9$
 $x = -3$

Draw a number line. Put an open dot at -3.

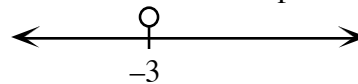

Test 0 and -4 in the original inequality.

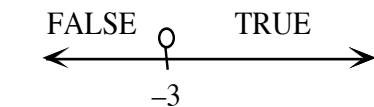

$$x = -4$$

$$x = 0$$

$$-2(-4) - 3 < -4 + 6$$

$$-2(0) - 3 < 0 + 6$$

$$8 - 3 < 2$$

$$-3 < 6$$

$$5 < 2$$

$$\text{TRUE}$$

FALSE

The solution is $x > -3$.

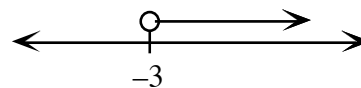

Problems

Solve each inequality.

1. $x + 3 > -1$

2. $y - 3 \leq 5$

3. $-3x \leq -6$

4. $2m + 1 \geq -7$

5. $-7 < -2y + 3$

6. $8 \geq -2m + 2$

7. $2x - 1 < -x + 8$

8. $2(m + 1) \geq m - 3$

9. $3m + 1 \leq m + 7$

Answers

1. $x > -4$

2. $y \leq 8$

3. $x \geq 2$

4. $m \geq -4$

5. $y < 5$

6. $m \geq -3$

7. $x < 3$

8. $m \geq -5$

9. $m \leq 3$

Measures of central tendency are numbers that locate or approximate the “center” of a set of data—that is, a “typical” value that describes the set of data. Mean and median are the most common measures of central tendency. (Mode will not be covered in this course.)

The mean is the arithmetic average of a data set. Add all the values in a set and divide this sum by the number of values in the set. The median is the middle number in a set of data arranged numerically. An outlier is a number that is much smaller or larger than most of the others in the data set. The range of a data set is the difference between the highest and lowest values of the data set.

For additional information, see the Math Notes box in Lesson 8.1.2 of the *Core Connections, Course 1* text.

The mean is calculated by finding the sum of the data set and dividing it by the number of elements in the set.

Example 1

Find the mean of this set of data: 34, 31, 37, 44, 38, 34, 42, 34, 43, and 41.

- $34 + 31 + 37 + 44 + 38 + 34 + 42 + 34 + 43 + 41 = 378$
- $\frac{378}{10} = 37.8$

The mean of this set of data is 37.8.

Example 2

Find the mean of this set of data: 92, 82, 80, 92, 78, 75, 95, and 77.

- $92 + 82 + 80 + 92 + 78 + 75 + 95 + 77 = 671$
- $\frac{671}{8} = 83.875$

The mean of this set of data is 83.875.

Problems

Find the mean of each set of data.

1. 29, 28, 34, 30, 33, 26, and 34.
2. 25, 34, 35, 27, 31, and 30.
3. 80, 89, 79, 84, 95, 79, 78, 89, 76, 82, 76, 92, 89, 81, and 123.
4. 116, 104, 101, 111, 100, 107, 113, 118, 113, 101, 108, 109, 105, 103, and 91.

The median is the middle number in a set of data *arranged in numerical order*. If there is an even number of values, the median is the mean (average) of the two middle numbers.

Example 3

Find the median of this set of data: 34, 31, 37, 44, 38, 34, 43, and 41.

- Arrange the data in order: 31, 34, 34, 37, 38, 41, 43, 44.
- Find the middle value(s): 37 and 38.
- Since there are two middle values, find their mean: $37 + 38 = 75$, $\frac{75}{2} = 37.5$. Therefore, the median of this data set is 37.5.

Example 4

Find the median of this set of data: 92, 82, 80, 92, 78, 75, 95, 77, and 77.

- Arrange the data in order: 75, 77, 77, 78, 80, 82, 92, 92, and 95.
- Find the middle value(s): 80. Therefore, the median of this data set is 80.

Problems

Find median of each set of data.

5. 29, 28, 34, 30, 33, 26, and 34.

6. 25, 34, 27, 25, 31, and 30.

7. 80, 89, 79, 84, 95, 79, 78, 89, 76, 82, 76, 92, 89, 81, and 123.

8. 116, 104, 101, 111, 100, 107, 113, 118, 113, 101, 108, 109, 105, 103, and 91.

The range of a set of data is the difference between the highest value and the lowest value.

Example 5

Find the range of this set of data: 114, 109, 131, 96, 140, and 128.

- The highest value is 140.
- The lowest value is 96.
- $140 - 96 = 44$.
- The range of this set of data is 44.

Example 6

Find the range of this set of data: 37, 44, 36, 29, 78, 15, 57, 54, 63, 27, and 48.

- The highest value is 78.
- The lowest value is 27.
- $78 - 27 = 51$.
- The range of this set of data is 51.

Problems

Find the range of each set of data in problems 5 through 8.

Outliers are numbers in a data set that are either much higher or much lower than the other numbers in the set.

Example 7

Find the outlier of this set of data: 88, 90, 96, 93, 87, 12, 85, and 94.

- The outlier is 12.

Example 8

Find the outlier of this set of data: 67, 54, 49, 76, 64, 59, 60, 72, 123, 44, and 66.

- The outlier is 123.

Problems

Identify the outlier in each set of data.

9. 70, 77, 75, 68, 98, 70, 72, and 71.
10. 14, 22, 17, 61, 20, 16, and 15.
11. 1376, 1645, 1783, 1455, 3754, 1790, 1384, 1643, 1492, and 1776.
12. 62, 65, 93, 51, 55, 14, 79, 85, 55, 72, 78, 83, 91, and 76.

Answers

- | | | | |
|--------------------------|----------------------------|---------------------------|----------------------------|
| 1. 30.57 | 2. $30\bar{3}$ | 3. $86.\bar{13}$ | 4. $106.\bar{6}$ |
| 5. median 30;
range 8 | 6. median 28.5;
range 9 | 7. median 82;
range 47 | 8. median 107;
range 27 |
| 9. 98 | 10. 61 | 11. 3754 | 12. 14 |

BOX PLOTS

Another way to display a distribution of one-variable numerical data is with a box plot. A box plot is the only display of data that clearly shows the median, quartiles, range, and outliers of a data set.

For additional information, see the Math Notes boxes in Lessons 8.1.4 and 8.1.5 of the *Core Connections, Course 1* text. For additional examples and practice, see the *Core Connections, Course 1* Checkpoint 9A materials.

Example 1

Display this data in a box plot:

51, 55, 55, 62, 65, 72, 76, 78, 79, 82, 83, 85, 91, and 93.

- Since this data is already in order from least to greatest, the range is $93 - 51 = 42$. Thus you start with a number line with equal intervals from 50 to 100.
- The median of the set of data is 77. A vertical segment is drawn at this value above the number line.
- The median of the lower half of the data (the lower quartile) is 62. A vertical segment is drawn at this value above the number line.
- The median of the upper half of the data (the upper quartile) is 83. A vertical segment is drawn at this value above the number line.
- A box is drawn between the upper and lower quartiles.
- Place a vertical segment at the minimum value (51) and at the maximum value (93). Use a line segment to connect the minimum to the box and the maximum to the box.

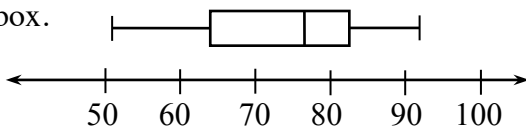

Example 2

Display this data in a box plot:

62, 65, 93, 51, 12, 79, 85, 55, 72, 78, 83, 91, and 76.

- Place the data in order from least to greatest: 12, 51, 55, 62, 65, 72, 76, 78, 79, 83, 85, 91, 93. The range is $93 - 12 = 81$. Thus you want a number line with equal intervals from 10 to 100.
- Find the median of the set of data: 76. Draw the line segment.
- Find the lower quartile: $55 + 62 = 117$; $117 \div 2 = 58.5$. Draw the line segment.
- Find the upper quartile: $83 + 85 = 168$; $168 \div 2 = 84$. Draw the line segment.
- Draw the box connecting the upper and lower quartiles. Place a line segment at the minimum value (12) and a line segment at the maximum value (93). Connect the minimum and maximum values to the box.

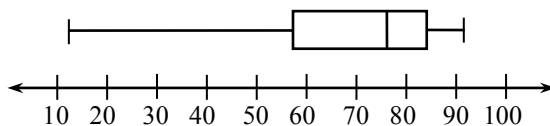

Problems

Create a stem-and-leaf plot and a box plot for each set of data in problems 1 through 4.

1. 45, 47, 52, 85, 46, 32, 83, 80, and 75.
 2. 75, 62, 56, 80, 72, 55, 54, and 80.
 3. 49, 54, 52, 58, 61, 72, 73, 78, 73, 82, 83, 73, 61, 67, and 68.
 4. 65, 35, 48, 29, 57, 87, 94, 68, 86, 73, 58, 74, 85, 91, 88, and 97.
5. Given a set of data: 265, 263, 269, 259, 267, 264, 253, 275, 264, 260, 273, 257, and 291.
 - a. Make a stem-and-leaf plot of this data.
 - b. Find the mean and median of this data.
 - c. Find the range of this data.
 - d. Make a box plot for this data.
 6. Given a set of data: 48, 42, 37, 29, 49, 46, 38, 28, 45, 45, 35, 46.25, 34, 46, 46.5, 43, 46.5, 48, 41.25, 29, and 47.75.
 - a. Make a stem-and-leaf plot of this data.
 - b. Find the mean and median of this data.
 - c. Find the range of the data.
 - d. Make a box plot for this data.

Answers

1.

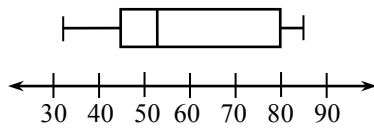
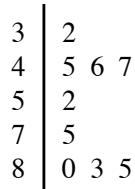

2.

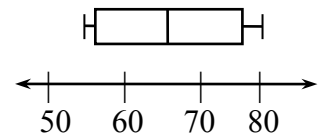
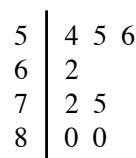

3.

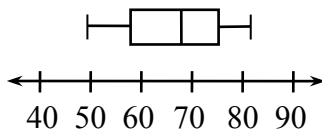
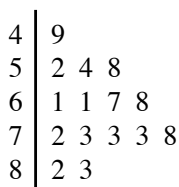

4.

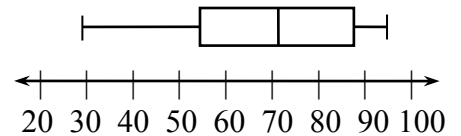
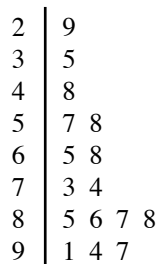

5.

25		3 7 9
26		0 3 4 4 5 7 9
27		3 5
28		
29		1

Mean: 266.15
Median: 264
Range: 38

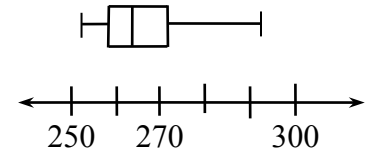

6.

2		8 9 9
3		4 5 7 8
4		1.25 2 3 5 5 6 6 6.25 6.5 6.5 7.75 8 8 9

Mean: 41.4405
Median: 43
Range: 21

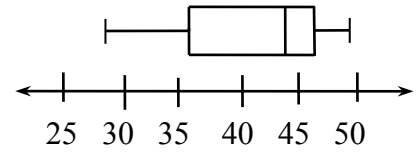

Initially, equations are solved either by applying math facts (for example, $4x = 12$, since $4 \cdot 3 = 12$, $x = 3$) or by matching equal quantities, simplifying the equation, and using math facts as shown in the examples below. Equations are often written in the context of a geometric situation.

Write an equation that represents each situation and find the value of the variable.

Example 1

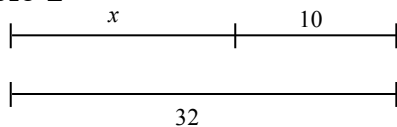

$$x + 10 = 32$$

$$x = 22$$

Example 2

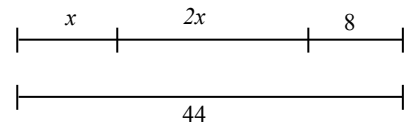

$$x + 2x + 8 = 44$$

$$x + 2x = 36$$

$$3x = 36$$

$$x = 12$$

Example 3

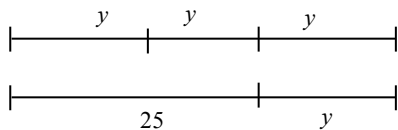

$$3y = 25 + y$$

$$2y = 25$$

$$y = 12.5$$

Example 4

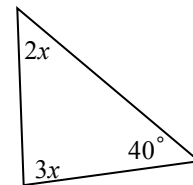

$$2x + 3x + 40 = 180$$

$$2x + 3x = 140$$

$$5x = 140$$

$$x = 18$$

Problems

Write an equation that represents each situation and then find the value of the variable.

1.

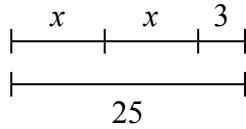

2.

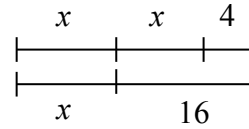

3.

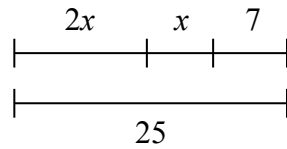

4.

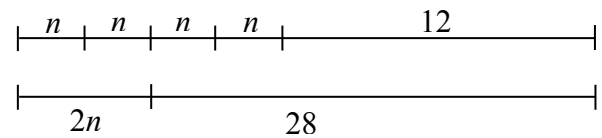

5.

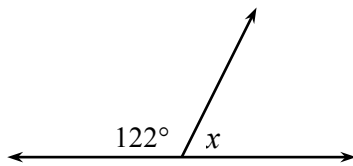

6.

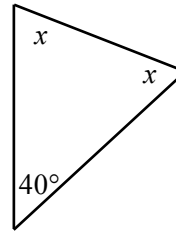

Solve each equation.

7. $x + 7 = -9$

8. $y - 2 = -3$

9. $-3y = 24$

10. $\frac{m}{2} = -6$

11. $3x + 2 = 11$

12. $4x + x + 5 = 25$

13. $m + 2m + 7 = m + 11$

14. $x + 9 + x + x = 30$

15. $3 - y = 9$

16. $4k + 1 = -7$

17. $x + 3x + x + 7 = 52$

18. $3m + 7 = m + 11$

19. $2(y + 3) = -12$

20. $3(c + 2) + c + 1 = 57$

Answers

1. $2x + 3 = 25; x = 11$
2. $2x + 4 = x + 16; x = 12$
3. $3x + 7 = 25; x = 6$
4. $4n + 12 = 2n + 28; n = 8$
5. $122 + x = 180; x = 58^\circ$
6. $2x + 40 = 180; x = 70^\circ$
7. $x = -16$
8. $y = -1$
9. $y = -8$
10. $m = -12$
11. $x = 3$
12. $x = 4$
13. $m = 2$
14. $x = 7$
15. $y = -6$
16. $k = -2$
17. $x = 9$
18. $m = 2$
19. $y = -9$
20. $c = 12.5$

Distance (d) equals the product of the rate of speed (r) and the time (t). This relationship is shown below in three forms:

$$d = r \cdot t \quad r = \frac{d}{t} \quad t = \frac{d}{r}$$

It is important that the units of measure are consistent. For additional information see the Math Notes box in Lesson 8.3.2 of the *Core Connections, Course 1* text.

Example 1

Find the rate of speed of a passenger car if the distance traveled is 572 miles and the time elapsed is 11 hours.

$$572 \text{ miles} = r \cdot 11 \text{ hours} \Rightarrow \frac{572 \text{ miles}}{11 \text{ hours}} = r \Rightarrow 52 \text{ miles/hour} = \text{rate}$$

Example 2

Find the distance traveled by a train at 135 miles per hour for 40 minutes.

The units of time are not the same so we need to change 40 minutes into hours. $\frac{40}{60} = \frac{2}{3}$ hour.

$$d = (135 \text{ miles/hour})\left(\frac{2}{3} \text{ hour}\right) \Rightarrow d = 90 \text{ miles}$$

Example 3

The Central Middle School hamster race is fast approaching. Fred said that his hamster traveled 60 feet in 90 seconds and Wilma said she timed for one minute and her hamster traveled 12 yards. Which hamster has the fastest rate?

rate = $\frac{\text{distance}}{\text{time}}$ but all the measurements need to be in the same units. In this example, we use feet and minutes.

Fred's hamster: rate = $\frac{60 \text{ feet}}{1.5 \text{ minutes}} \Rightarrow \text{rate} = 40 \text{ feet/minute}$

Wilma's hamster: rate = $\frac{36 \text{ feet}}{1 \text{ minute}} \Rightarrow \text{rate} = 36 \text{ feet/minute}$

Fred's hamster is faster.

Problems

Solve the following problems.

1. Find the time if the distance is 157.5 miles and the speed is 63 mph.
2. Find the distance if the speed is 67 mph and the time is 3.5 hours.
3. Find the rate if the distance is 247 miles and the time is 3.8 hours.
4. Find the distance if the speed is 60 mph and the time is 1 hour and 45 minutes.
5. Find the rate in mph if the distance is 3.5 miles and the time is 20 minutes.
6. Find the time in minutes if the distance is 2 miles and the rate is 30 mph.
7. Which rate is faster? A: 60 feet in 90 seconds or B: 60 inches in 5 seconds
8. Which distance is longer? A: 4 feet/second for a minute or B: 3 inches/min for an hour
9. Which time is shorter? A: 4 miles at 60 mph or B: 6 miles at 80 mph

Answers

1. 2.5 hr 2. 234.5 mi 3. 65 mph 4. 105 miles 5. 10.5 mph
6. 4 min 7. B 8. A 9. A

VOLUME OF A PRISM

Volume is a three-dimensional concept. It measures the amount of interior space of a three-dimensional figure based on a cubic unit, that is, the number of 1 by 1 by 1 cubes that will fit inside a figure.

The volume of a prism is the area of either base (B) multiplied by the height (h) of the prism.

$$V = (\text{Area of base}) \cdot (\text{height}) \text{ or } V = Bh$$

For additional information, see the Math Notes box in Lesson 9.2.1 of the *Core Connections, Course 1* text.

Example 1

Find the volume of the square prism below.

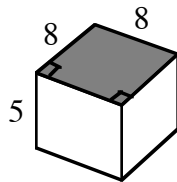

The base is a square with area (B)
 $8 \cdot 8 = 64 \text{ units}^2$.

$$\begin{aligned} \text{Volume} &= B(h) \\ &= 64(5) \\ &= 320 \text{ units}^3 \end{aligned}$$

Example 2

Find the volume of the triangular prism below.

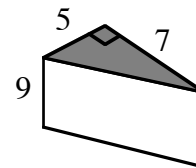

The base is a right triangle with area
 $\frac{1}{2}(5)(7) = 17.5 \text{ units}^2$.

$$\begin{aligned} \text{Volume} &= B(h) \\ &= 17.5(9) \\ &= 157.5 \text{ units}^3 \end{aligned}$$

Example 3

Find the volume of the trapezoidal prism below.

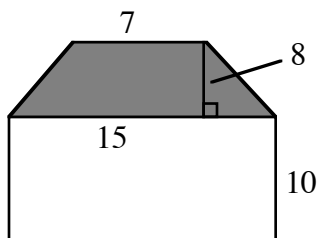

The base is a trapezoid with area
 $\frac{1}{2}(7 + 15) \cdot 8 = 88 \text{ units}^2$.

$$\begin{aligned} \text{Volume} &= B(h) \\ &= 88(10) \\ &= 880 \text{ units}^3 \end{aligned}$$

Example 4

Find the height of the prism with a volume of 132.5 cm^3 and base area of 25 cm^2 .

$$\begin{aligned} \text{Volume} &= B(h) \\ 132.5 &= 25(h) \\ h &= \frac{132.5}{25} \\ h &= 5.3 \text{ cm} \end{aligned}$$

Problems

Calculate the volume of each prism. The base of each figure is shaded.

1. Rectangular Prism

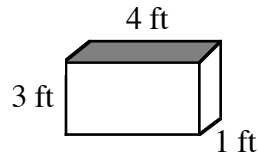

2. Right Triangular Prism

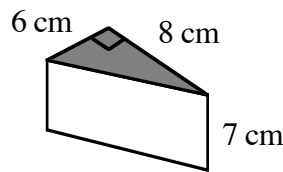

3. Rectangular Prism

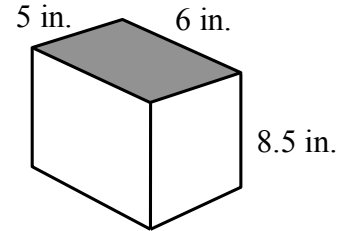

4. Right Triangular Prism

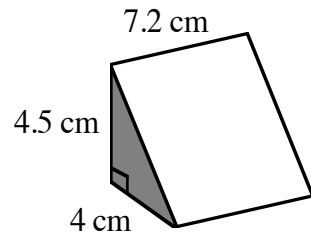

5. Trapezoidal Prism

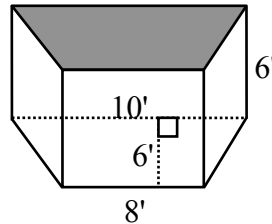

6. Triangular Prism with $B = 15\frac{1}{2} \text{ cm}^2$

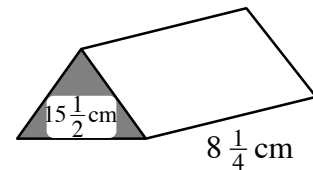

7. Find the volume of a prism with base area 32 cm^2 and height 1.5 cm .
8. Find the height of a prism with base area 32 cm^2 and volume 176 cm^3 .
9. Find the base area of a prism with volume 47.01 cm^3 and height 3.2 cm .

Answers

1. 12 ft^3
2. 168 cm^3
3. 240 in.^3
4. 64.8 cm^3
5. 324 ft^3
6. $127\frac{7}{8} \text{ cm}^3$
7. 48 cm^3
8. 5.5 cm
9. 14.7 cm^2

SURFACE AREA OF A PRISM

The surface area of a prism is the sum of the areas of all of the faces, including the bases. Surface area is expressed in square units.

For additional information, see the Math Notes boxes in Lessons 9.2.1 and 9.2.2 of the *Core Connections, Course 1* text.

Example

Find the surface area of the triangular prism at right.

Step 1: Area of the 2 bases: $2 \left[\frac{1}{2} (6 \text{ cm})(8 \text{ cm}) \right] = 48 \text{ cm}^2$

Step 2: Area of the 3 lateral faces

$$\text{Area of face 1: } (6 \text{ cm})(7 \text{ cm}) = 42 \text{ cm}^2$$

$$\text{Area of face 2: } (8 \text{ cm})(7 \text{ cm}) = 56 \text{ cm}^2$$

$$\text{Area of face 3: } (10 \text{ cm})(7 \text{ cm}) = 70 \text{ cm}^2$$

Step 3: Surface Area of Prism = sum of bases and lateral faces:

$$\text{SA} = 48 \text{ cm}^2 + 42 \text{ cm}^2 + 56 \text{ cm}^2 + 70 \text{ cm}^2 = 216 \text{ cm}^2$$

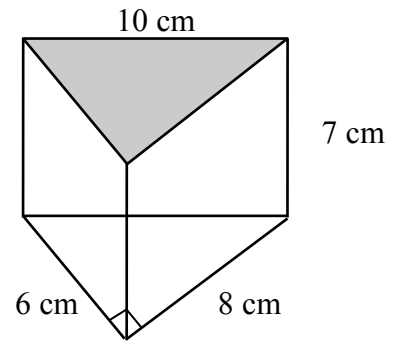

Problems

Find the surface area of each prism.

1.

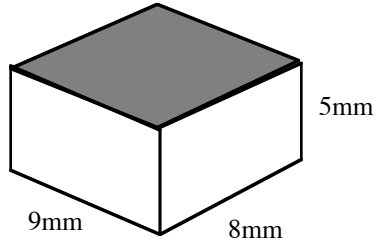

2.

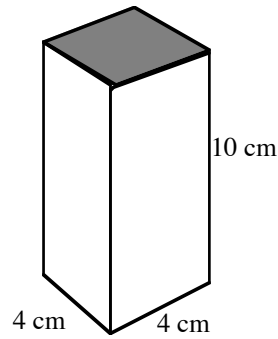

3.

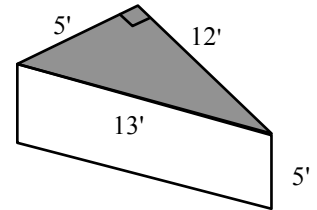

4.

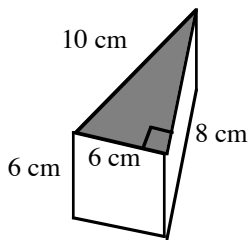

5. The pentagon is equilateral.

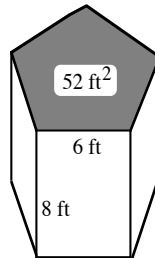

6.

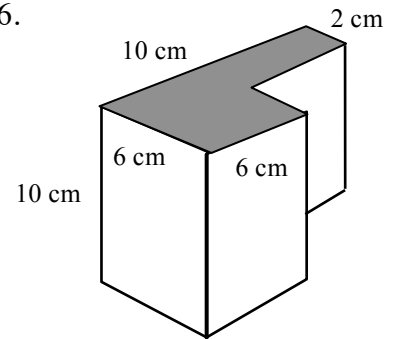

Answers

1. 314 mm^2

2. 192 cm^2

3. 210 ft^2

4. 192 cm^2

5. 344 ft^2

6. 408 cm^2

Students also calculate percentages by composition and decomposition, that is, breaking numbers into parts, and then adding or subtracting the results. This method is particularly useful for doing mental calculations. A percent ruler is also used for problems when you need to find the percent or the whole.

For additional information, see the Math Notes box in Lesson 9.2.4 of the *Core Connections, Course 1* text.

Knowing quick methods to calculate 10% of a number and 1% of a number will help you to calculate other percents by composition. Use the fact that $10\% = \frac{1}{10}$ and $1\% = \frac{1}{100}$.

Example 1

To calculate 32% of 40, you can think of $3(10\% \text{ of } 40) + 2(1\% \text{ of } 40)$.

$10\% \text{ of } 40 \Rightarrow \frac{1}{10} \text{ of } 40 = 4$ and $1\% \text{ of } 40 \Rightarrow \frac{1}{100} \text{ of } 40 = 0.4$ so

$32\% \text{ of } 40 \Rightarrow 3(4) + 2(0.4) \Rightarrow 12 + 0.8 = 12.8$

Example 2

To calculate 9% of 750, you can think of $10\% \text{ of } 750 - 1\% \text{ of } 750$.

$10\% \text{ of } 750 \Rightarrow \frac{1}{10} \text{ of } 750 = 75$ and $1\% \text{ of } 750 \Rightarrow \frac{1}{100} \text{ of } 750 = 7.5$ so

$9\% \text{ of } 750 \Rightarrow 75 - 7.5 = 67.5$

Other common percents such as $50\% = \frac{1}{2}$, $25\% = \frac{1}{4}$, $75\% = \frac{3}{4}$, $20\% = \frac{1}{5}$ may also be used.

Students also use a percent ruler to find missing parts in percent problems.

Example 3

Jana saved \$7.50 of the original price of a sweater when it was on sale for 20% off. What was the original price of the sweater?

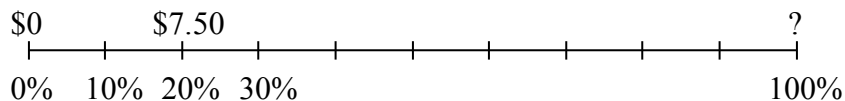

If every 20% is \$7.50, the other four 20% parts ($4 \cdot 7.50 + 7.50$) find that 100% is \$37.50.

Example 4

To calculate 17% of 123.4 convert the percent to a decimal and then use direct computation by hand or with a calculator.

$$17\% \text{ of } 123.4 \Rightarrow \frac{17}{100} (123.4) \Rightarrow 0.17(123.4) = 20.978$$

Problems

Solve each problem without a calculator. Show your work or reasoning.

1. What is 22% of 60?
2. What is 29% of 500?
3. What is 41% of 82?
4. What is 8% of 65?
5. 45 is 30% of what number?
6. \$1.50 is 25% of what amount?
7. 60 is what % of 80?
8. What is 15% of 32?
9. What percent is 16 out of 20?
10. \$10 is what percent of \$25?
11. 30% of what number is 27
12. 15% of what number is 24?

Compute by any method. Round to the nearest cent as appropriate.

13. 17% of 125.8
14. 32% of 4.825
15. 125% of 49
16. 6.5% of 48
17. 5.2% of 8.7
18. 7% of \$14.95
19. 9% of \$32.95
20. 1.5% of \$3200
21. 1.65% of \$10,500
22. 120% of 67
23. 167% of 45.8
24. 15% of \$24.96
25. 20% of 32
26. 2.5% of 1400
27. 3.6% of 2450

Answers

1. 13.2
2. 145
3. 33.62
4. 52
5. 150
6. \$6.00
7. 75%
8. 4.8
9. 80%
10. 40%
11. 90
12. 160
13. 21.386
14. 1.544
15. 61.25
16. 3.12
17. 0.4524
18. \$1.05
19. \$2.97
20. \$48
21. \$173.25
22. 80.4
23. 76.486
24. \$3.74
25. 6.4
26. 35
27. 88.2